

PSI-X-1PMETER-ZI

METER FOR INVERTER
MONOPHASE X1

User Manual



/// PEIMAR

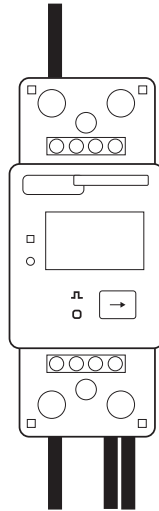

Single-Phase Meter PSI-X-1P-METER-ZI

Premise

The meter is a device that allows you to analyze the energy flow of the system to manage it in the most appropriate way; The meter compatible with the single-phase inverters of the PSI-1XP (TP-TPM-HY) series and for currents up to 80 A is the PSI-X-1PMETER-ZI with direct insertion.

The installation of the PSI-X-1PMETER-ZI meter therefore allows you to:

- Monitor self-consumption during daylight hours on the inverter display or on the monitoring portal;
- Read consumption in real time on the meter display;
- Set the power “Export Limit” function which, if enabled, allows the system to block the feeding of excess energy into the grid; if, on the other hand, the “Export Limit” function is disabled (Default value), the energy not self-consumed by the users will be fed into the grid.



PLEASE NOTE

Check that an "X" is indicated next to the product label.

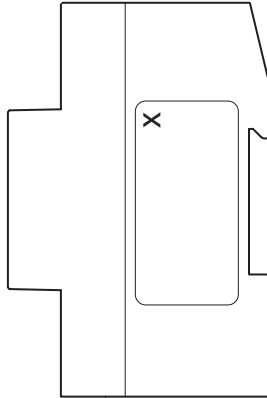

PLEASE NOTE

The PSI-X-X1PMETER-ZI must be installed upstream of the mains loads, downstream of the exchange meter; Refer to the diagram below for the exact installation point (see generic diagram below).

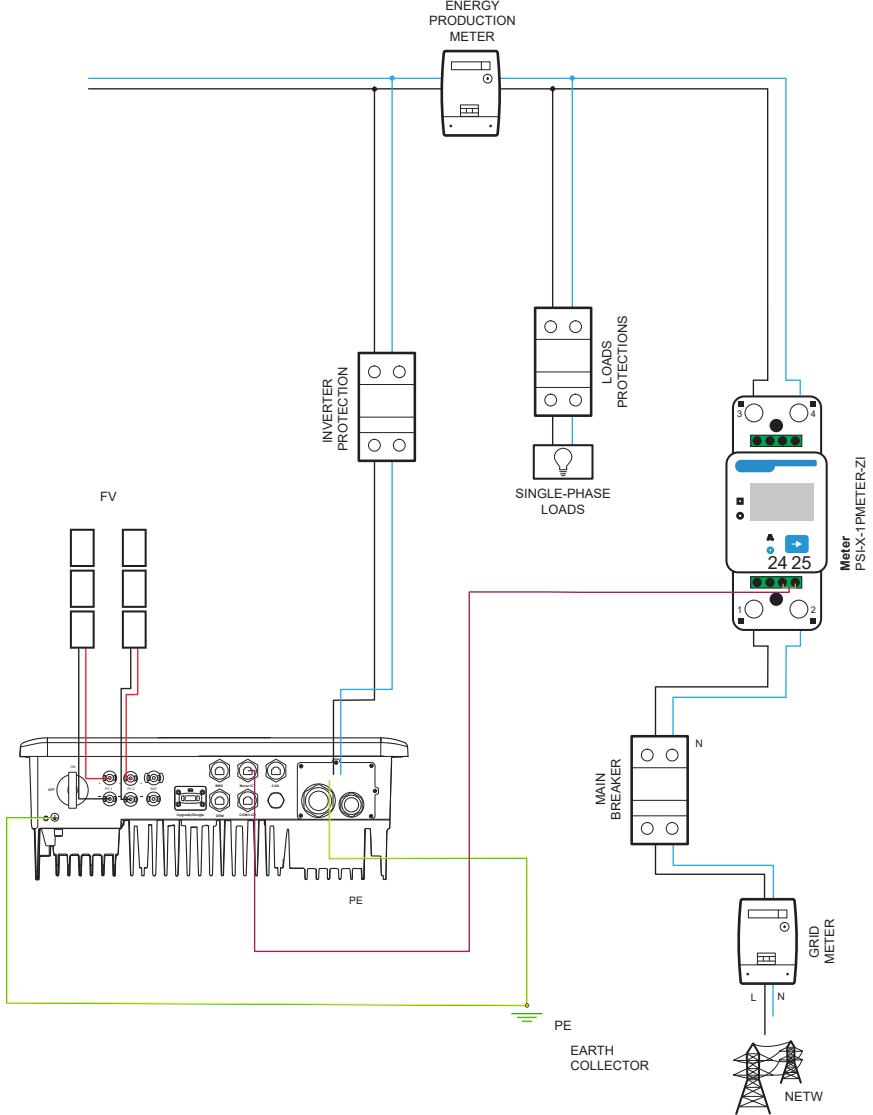



PLEASE NOTE

The position of the energy meter and the protections indicated in the diagram are purely indicative and to be evaluated in agreement with the designer on the basis of the regulations in force at the time of installation and any other existing systems.

Installation Meter PSI-X-1PMETER-ZI

To connect the PSI-X-3PMETER-HY meter, follow the mounting procedure:



WARNING

Make sure you have cut off the AC side power on the system line.

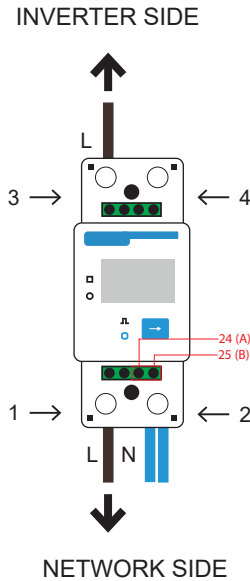

- 1 - 3 are the pins of the Line.
- 2 - 4 are the pins of the Neutral.
- 24 - 25 are the pins of the communication cable.

1. Strip the phase (L) coming from the exchange counter (mains side) by 8-10mm and fix it to input 1 of the meter by tightening the clamp
2. Strip the phase (L) coming from the system (inverter side) by 8-10mm and fix it at input 3 of the meter;
3. Strip the neutral coming from the exchange counter and the system by 8-10mm and fix them to the input 2 of the meter by tightening the clamp. It is also possible to connect the neutral incoming from the system (inverter side) to output 4 of the meter.



PLEASE NOTE

The size of the network cables for the meter connection must have a cross-section $\leq 16.00 \text{ mm}^2$.

4. Arrange a twisted pair cable of sufficient length to cover the distance between the inverter and the meter, otherwise use an RS485 cable of suitable length. Insert the two wires of a terminal, stripping them beforehand, into outputs 24 (A) and 25 (B) of the meter and then secure them by tightening the clamp.



PLEASE NOTE

The size of the meter's communication cable must have at least one cross-section between 0.25 and 1.00 mm^2 .

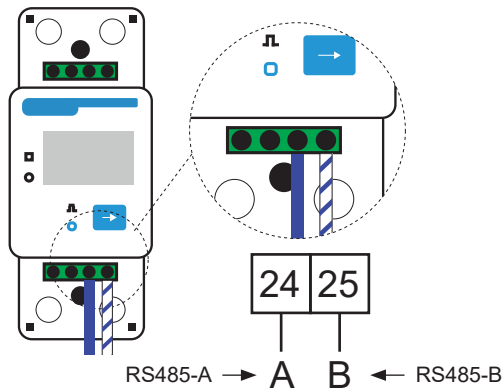

5. For connection on the inverter side, please refer to the relevant inverter manual and the paragraphs below;
6. Once the electrical connection phase has been completed, fix the PSI-X-1PMETER-ZI meter on DIN rails (height 35 mm). Since the meter is neither waterproof nor dustproof, it is recommended to install it inside the electrical panel;
7. The display of the PSI-X-1PMETER-ZI meter lights up when the system is energized. The meter is already automatically set with the correct network parameters; By briefly pressing the “arrow” key, you can scroll through and check the different parameters set; The meter is already pre-set with the correct operating parameters, which therefore do not need to be modified.

PSI-X1P Series Single-Phase Grid Inverter Connection (TL-TLM)

The following installation procedure applies to the single-phase grid inverters of the series PSI-X1P-TL and PSI-X1P-TLM.

To connect the meter to the inverter, use the communication port called RS485 located on the underside of the inverter.

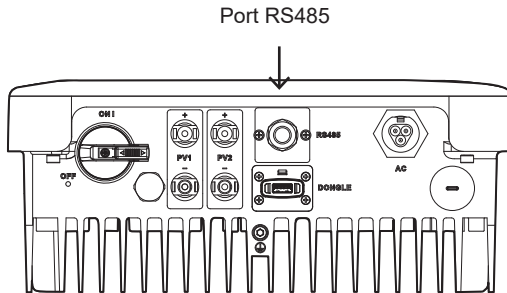

1. Take the connection cable and after connecting the two ends to the meter in the respective ports (24 and 25, see previous chapter) proceed to crimp the two wires of the other end of the cable to an RJ45 plug so that there is continuity between:
 - Meter terminal 24 (A) and plug pin 4
 - Meter Terminal 25 (B) and Plug Pin 5

If a standard RS485 communication cable (not included in the package) is used, connect the blue wire to terminal 24 and the white-blue wire to terminal 25 of the meter; from the inverter side, crimp the blue wire to Pin 4 of the plug and the white-blue wire to Pin 5 of the plug.

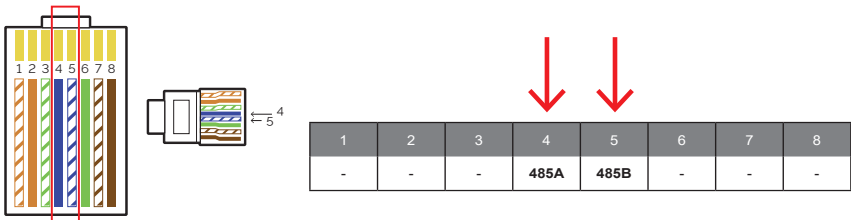

2. Connect the RJ45 plug to the RS485 port of the inverter.

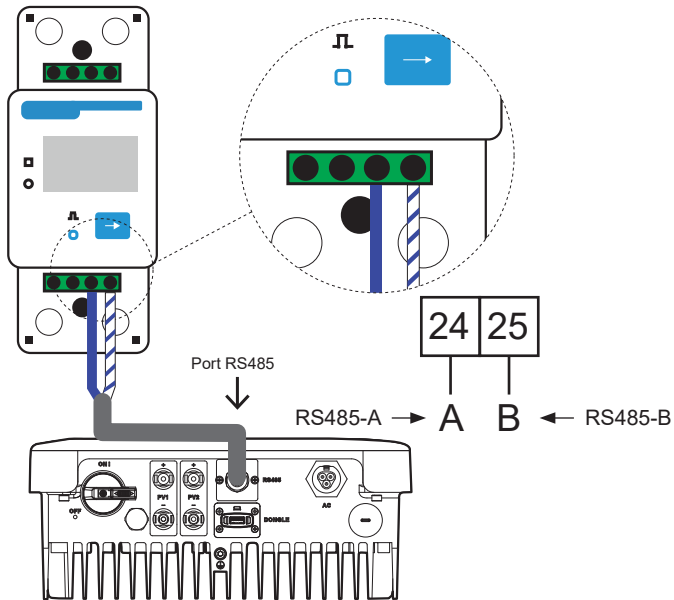

3. In order for the PSI-X-1PMETER-ZI meter to work properly, the correct setting must be selected on the PSI-1XP grid inverter. From the display, go to the menu and select Meter:

MENU > OPTIONS > "2014" Password > Export Control > Select > Meter Mode > Enable.

To activate the export limit function and ensure that no energy is exported to the grid, activate the appropriate option in the inverter's advanced settings; From the Display, go to the menu:

MENU > OPTIONS > Password "2014" > Export Control > Select Mode > Meter > 0W.

PSI-X1P Series Hybrid Single Phase Inverter Connection (HY)

The following installation procedure applies to the PSI-X1P-HY series hybrid single-phase inverters. To connect the meter to the inverter, you must use the communication port called Meter/CT located on the underside of the hybrid inverter.

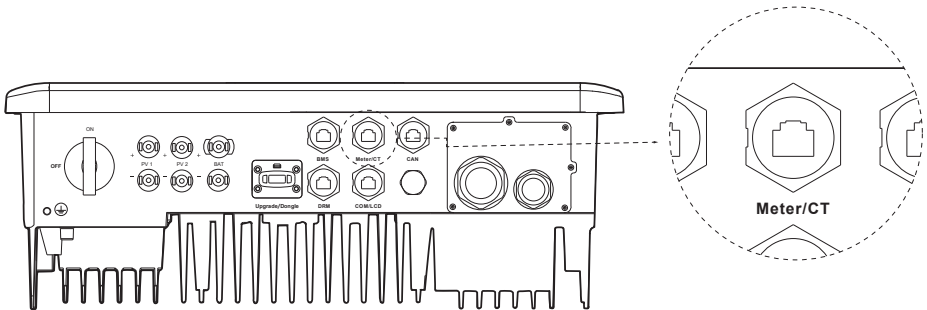

1. Take the connection cable and after connecting the two ends to the meter in the respective ports (24 and 25, see previous chapter) proceed to crimp the two wires of the other end of the cable to an RJ45 plug so that there is continuity between:
 - Meter terminal 24 (A) and plug pin 4
 - Meter Terminal 25 (B) and Plug Pin 5

If a standard RS485 communication cable (not included in the package) is used, connect the blue wire to terminal 24 and the white-blue wire to terminal 25 of the meter; from the inverter side, crimp the blue wire to Pin 4 of the plug and the white-blue wire to Pin 5 of the plug.

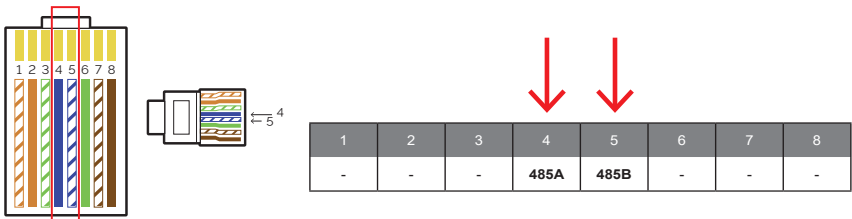

2. Insert the other end of the cable into the inverter's meter port by unscrewing the grommet and inserting it through the waterproof gasket.

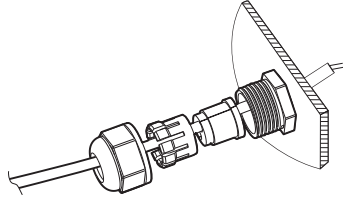

3. Finally, connect the RJ45 plug into the Meter/CT port of the inverter:

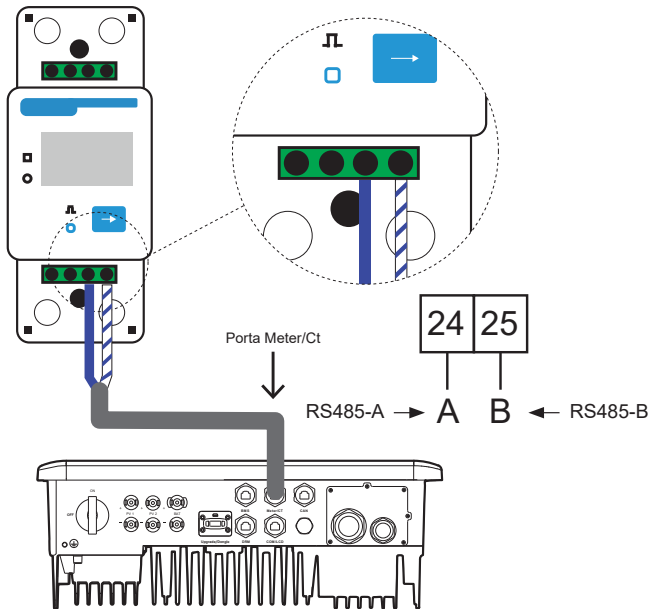

4. In order for the PSI-X-1PMETER-ZI meter to work correctly, it is necessary to select the correct setting on the hybrid inverter;

From the display, go to the menu and select Meter:

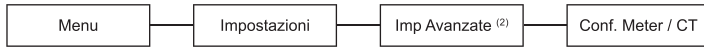

⁽²⁾ Password "2014"

To activate the export limit function and ensure that no energy is exported to the grid, activate the appropriate option in the inverter's advanced settings; From the Display, go to the menu:

MENU > SETTINGS > ADVANCED SETTINGS (Password "2014") > EXPORT CONTROL > 0W.

It should be noted that the technical data, information and representations contained in this document are purely indicative. Peimar reserves the right to modify the data, drawings and information contained in this document at any time and without prior notice.

/// PEIMAR



info@peimar.com | www.peimar.com