

PSI-X-3PMETER-HY-CT

METER FOR THREE-PHASE
INVERTER X3

User Manual



/// PEIMAR

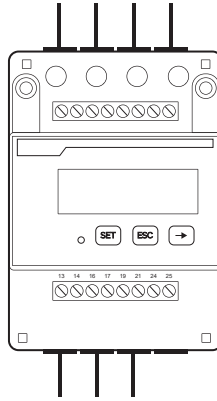

Meter connection with CT

Meter PSI-X-3PMETER-HY-CT

The meter is a device that allows you to analyze the energy flow of the system to manage it appropriately; the meter is compatible with three-phase inverters of the PSI-X3P (TP-TPM-HY) and PSI-X3S (HY) series for currents up to 200A is the PSI-X-3PMETER-HY-CT.

The meter also allows you to set the “Export Control” function which defines the power transferred to the grid. By default, the energy produced that is not self-consumed by the plant will be fed into the grid; if the user does not want to transfer power to the grid, he will have to set the value “0 Watt” in the advanced options of the inverter.

The Meter must be installed upstream of all network loads, downstream of the exchange meter; refer to the diagram below (the position of the energy meter produced and of the protections indicated in the diagram are purely indicative and to be evaluated in agreement with the designer on the basis of the regulations in force at the time of installation and of any other existing systems):

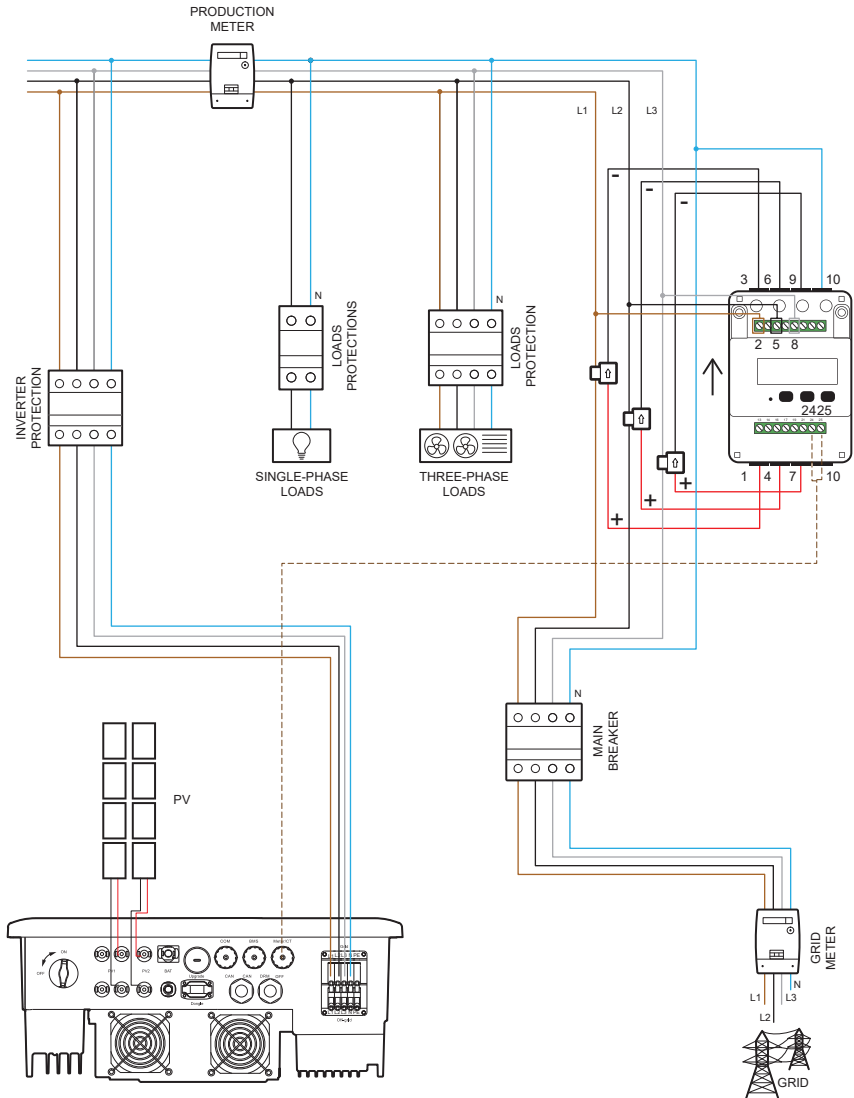

For the connection of the PSI-X-3PMETER-HY-CT meter observe the following assembly procedure:



PLEASE NOTE

Make sure you have cut off the AC side power on the utility line.

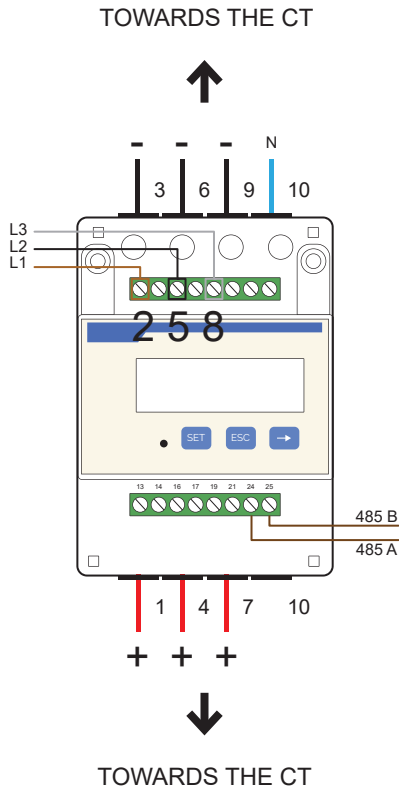

1. Create a derivation of the three phases arriving from the exchange meter, strip them of 8-10mm and fix them respectively to inputs 2, 5 and 8 of the meter by tightening the terminal; the cable should have a section of 0.25~1 mm² (17~23AWG).

2. Fix the three positive (red) cables of the 3 CT's respectively to outputs 1, 4 and 7 of the meter by tightening the clamp; repeat the procedure for the three negative cables (black) and fix them to outputs 3, 6 and 9 of the meter as shown in the figure.
3. Strip the neutral cable arriving from the exchange meter (mains side) by 8-10 mm and secure it to input 10.
4. Position the 3 CT's, hooking them around the cables of the three phases, paying attention to the direction of the arrow (the arrow on the CT must point towards the inverter). Check the correspondence of the wiring of the different lines:
 - The CT connected to ports 1 and 3 must be hooked around the line cable connected to port 2 of the meter (L1 on the image).
 - The CT connected to ports 6 and 4 must be hooked around the line cable connected to port 5 of the meter (L2 on the image).
 - The CT connected to ports 7 and 9 must be hooked around the line cable connected to port 8 of the meter (L3 on the image).

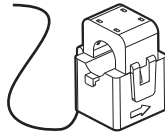

5. Lay a twisted-pair cable long enough to cover the distance between the inverter and the meter (a 10m cable is included in the package). Insert the two wires of a terminal into outputs 24 and 25 of the meter and fix them by tightening the clamp.
6. For the connection on the inverter side, refer to the manual of the specific model (see paragraphs below).
7. Once the electrical connection phase has been completed, fix the PSI-X-3PMETER-HY-CT meter on 35 mm guides. Since the meter is neither waterproof nor dustproof, it is recommended to install it inside the electrical panel.
8. The display of the PSI-X-3PMETER-HY-CT meter lights up when voltage is supplied to the system.
9. The meter is already automatically set with the correct network parameters; by briefly pressing the "arrow" key it is possible to scroll and check the various parameters.

Three-phase hybrid inverter PSI-X3S (HY)

1. Crimp the two wires of the other end of the cable to an RJ45 plug so that there is continuity between:
 - Clamp 24 of the meter and Pin 4 of the plug.
 - Clamp 25 of the meter and Pin 5 of the plug.

If an RS485 communication cable is used, connect the blue wire to terminal 24 and the white/blue wire to terminal 25 of the meter; from the inverter side, crimp the blue wire to Pin 4 of the plug and the white-blue wire to Pin 5 of the plug.

Refer to the diagram below:

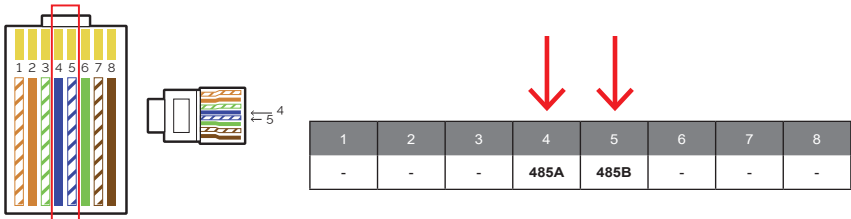

2. Connect the RJ45 plug to the Meter/CT port.

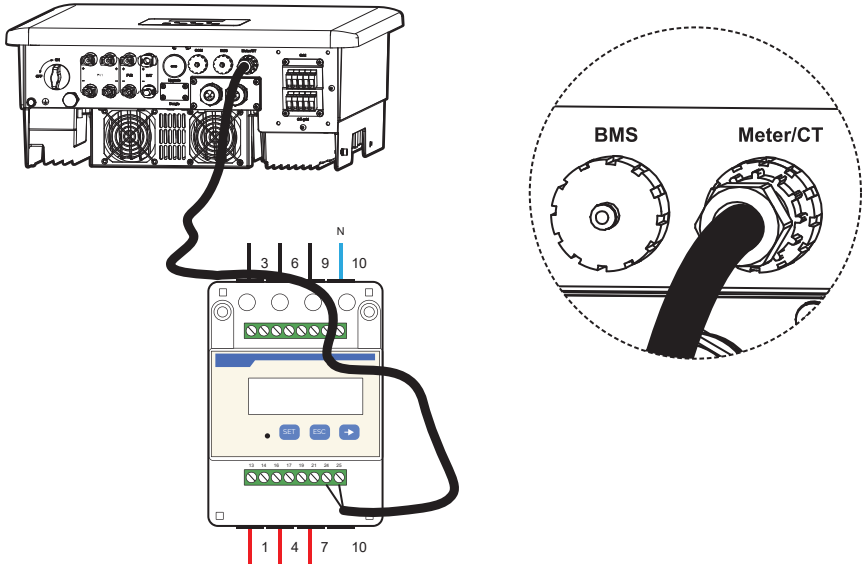

3. In order for the PSI-X-3PMETER-HY meter to work correctly, it is necessary to select the correct setting on the inverter; from the display go to the menu:
MENU > OPTIONS > Password "2014" > ADVANCE > CT / Meter Setting > meter

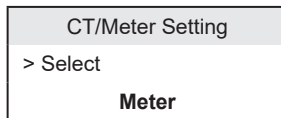

Three Phase Hybrid Inverter PSI-X3P (HY)

1. Insert the other end of the cable into the meter port of the inverter by unscrewing the cable gland and inserting it through the waterproof gasket.

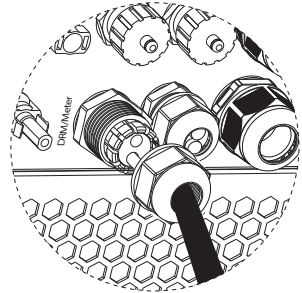
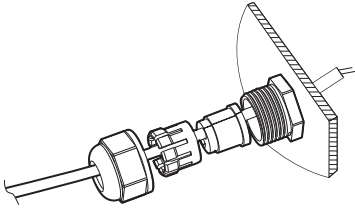

2. Fix the incoming wire from terminal 24 of the meter to pin 1 of the green 8-pin terminal block included in the inverter package
3. Fix the incoming wire from terminal 25 of the meter to pin 2 of the green 8-pin terminal block included in the inverter package
4. Clip and screw the eight-pin connector into the dedicated port inside the inverter. Refer to the following drawing.

(Torque: $0.2 \pm 0.1 \text{ Nm}$)

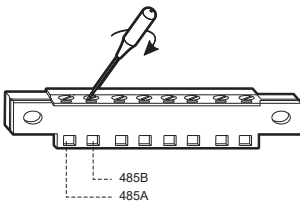

(Torque: $0.4 \pm 0.1 \text{ Nm}$)

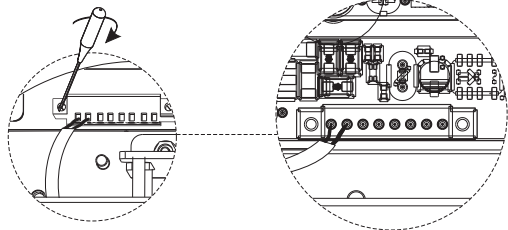

Three-phase hybrid inverter PSI-X3P 6-8-10 kW (TP)

1. Crimp the two wires of the other end of the cable to an RJ45 plug so that there is continuity between:

- Terminal 24 of the meter and Pin 4 of the plug
- Terminal 25 of the meter and Pin 5 of the plug

If an RS485 communication cable is used, connect the blue wire to terminal 24 and the white/blue wire to terminal 25 of the meter; from the inverter side, crimp the blue wire to Pin 4 of the plug and the white-blue wire to Pin 5 of the plug.

Refer to the diagram below:

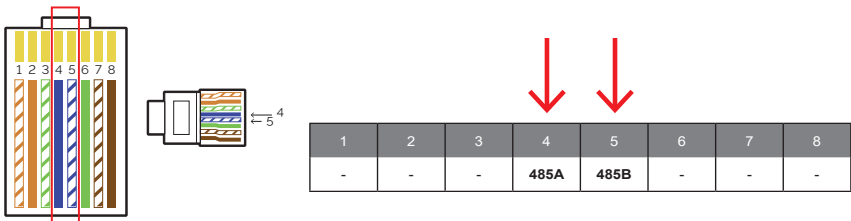

- 2. Connect the RJ45 plug to the RS485 port of the inverter.

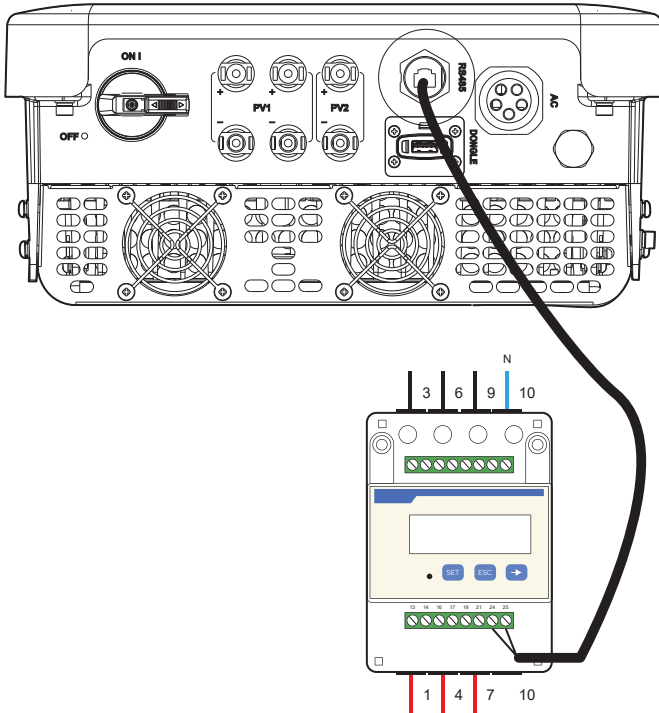

- 3. To activate the export limit function, activate the appropriate option in the advanced settings of the inverter; from the display go to the menu:
MENU > OPTIONS > Password "2014" > EXPORT CONTROL > MODE > METER > 0 W.

```
=== Export Control ===  
> Mode Select  
Meter/Disable
```

PSI-X3P Three-Phase Grid Inverter 15-20-30 kW (TPM)

1. Insert the other end of the cable into the RS485 port of the inverter by unscrewing the grommet and inserting it through the waterproof seal.

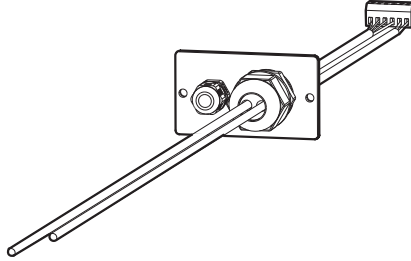

2. Secure the incoming wire from terminal 24 of the meter to pin 5 (meter A) of the 6-pin terminal block included in the inverter package.
3. Attach the incoming wire from terminal 25 of the meter to pin 6 (meter B) of the 6-pin terminal block included in the inverter package.
4. Hook and screw the eight-pin connector into the dedicated port inside the inverter. Refer to the following drawing:

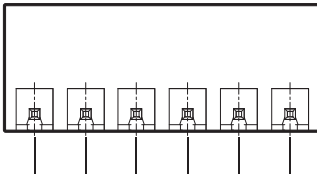
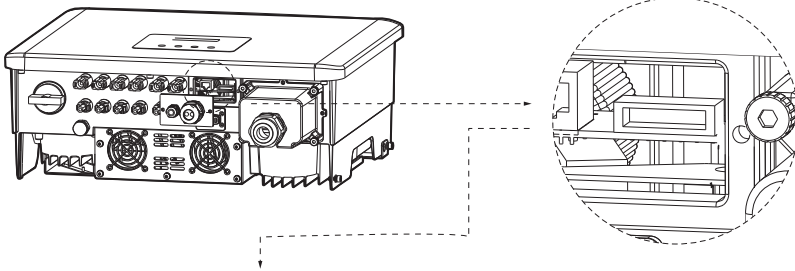

Pin	1	2	3	4	5	6
Definition	485A	485B	485A	485B	meter A	meter B

5. To activate the export limit function, activate the export limit option in the advanced settings of the inverter: From the display go to the menu:

MENU > OPTIONS > Password "2014" > EXPORT CONTROL > MODE > METER > 0W.

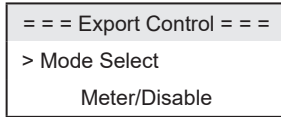

Three Phase Grid Inverter PSI-X3P (TPM) 40-50-60 KW and 100-125 KW

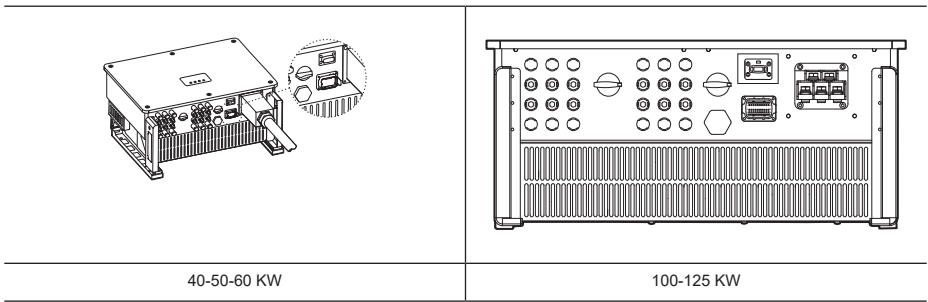

RS-485-2	7	RS485A METER	Connect the RS485 Meter or other devices.
	8	RS485B METER	

Communication cable for communication with the inverter

- Connection
 - a) Take the communication terminal out of the box and separate the respective parts as shown.

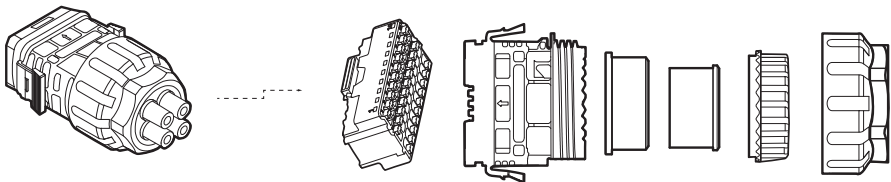

- b) Take a communication cable, strip two wires of 12-14 mm and connect them to PIN 7 and PIN 8 of the 30 PIN housing.

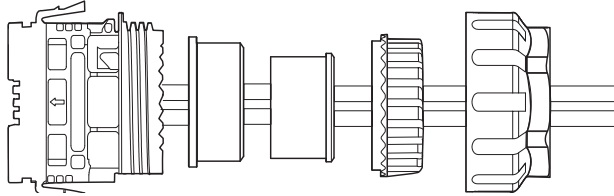

- c) Then insert the head of the connector until you hear a “Click” which indicates that it has been hooked up.

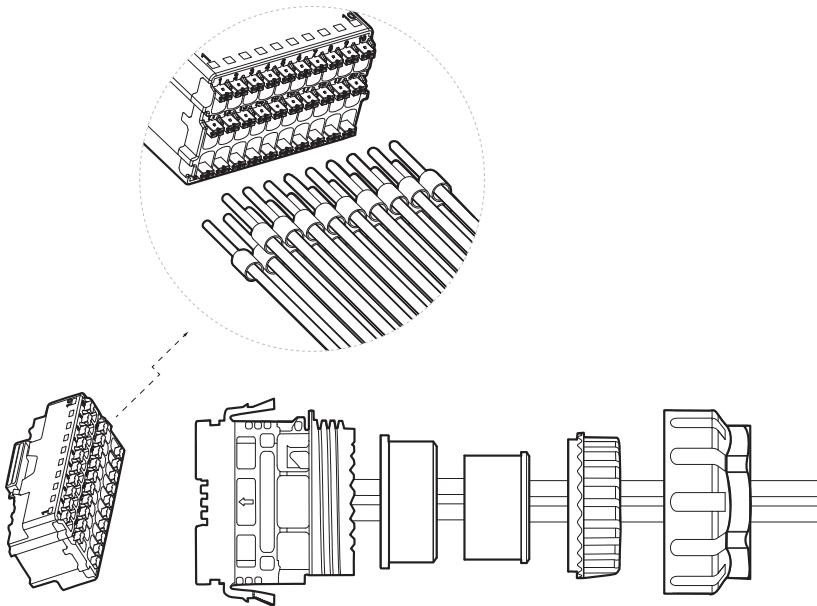

- d) Push the connector body onto the sealing ring and then insert the nut.
e) Screw the ring nut until its tight.
f) Insert the connector thus assembled into the COM Port of the inverter.

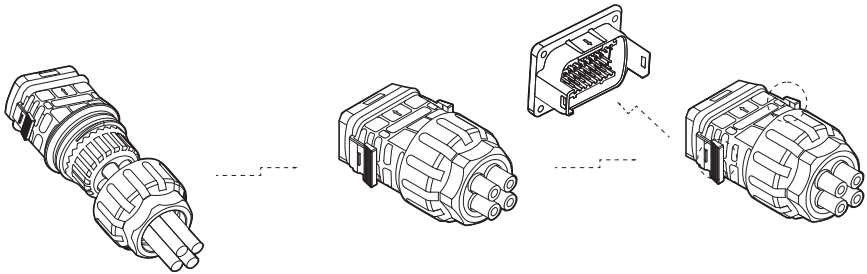

To disconnect the connector, press the side buttons together.



PLEASE NOTE

Crimp the two wires of the other end of the cable to the meter, so that there is continuity between:

- Clamp 24 of the meter and Pin 7 (RS485A) of the plug.
- Clamp 25 of the meter and Pin 8 (RS485B) of the plug.

See the diagram below.

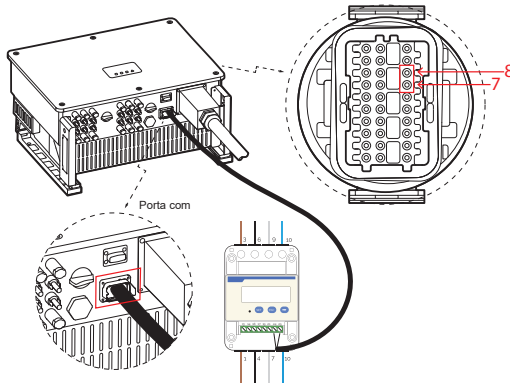

It is important to point out, that all technical specifications, information and figures contained in this datasheet are estimated values. Peimar reserves the right to change the technical specifications, information and figures contained in this document at any time without notice.

/// PEIMAR



info@peimar.com | www.peimar.com