

PSI-X1P8000-TLS (A) EN PSI-X1P10000-TLS (A)

SINGLE PHASE ON GRID INVERTER

User manual



/// PEIMAR

It should be noted that the technical data, information and representations contained in this document have a purely indicative value. Peimar reserves the right to modify the data, drawings and information contained in this document at any time and without notice.

/// PEIMAR

1. Safety Measures	6
1.4. Descriptions of Labels	7
1.3. Proper Usage	9
1.3. Important safety instructions	10
1.5. PE Connection and leakage Current	12
2. Product Information	13
2.1. Basic Features	13
2.2. Product Model Specifications PSI-X1PXXXX-TLS (A):	13
2.3. Product Dimension	14
2.4. Component List	14
2.5. Terminals of the Inverter	16
3. Installation instructions	17
3.1. Installation Precaution	17
3.2. Packaging Control	18
3.2. Installation and placement procedure	18
3.5. Mounting procedure	19
3.6. Connections of the Inverter	22
4. Commissioning	51

5. Parallel Connection	52
5.1. Parallel System with Datahub	54
6. Operation	56
6.1. Control Panel	56
6.2. LCD Structure	57
6.3. LCD Internal Menus	63
6.4. Inverter Functions	72
7. Monitoring System Configuration	74
7.1. Configuration via Wi-Fi module	74
7.1.1. Configuration using the Wi-Fi module from the browser	75
7.1.2. Configuration via Wi-Fi module from the app	77
7.2. Configuration via Ethernet cable (LAN) with PSI-X-H-ETH-3.0	79
8. Troubleshooting	80
8.1. Maintenance Routine	85
9. Disposal	86
10. Warranty Conditions	86

Scope of Validity

This user manual contains detailed instructions and procedures for the installation, operation, maintenance and troubleshooting of the following grid connected Peimar inverters:

PSI-X1P8000-TLS (A)	PSI-X1P10000-TLS (A)
---------------------	----------------------



NOTICE

If the name of the series of the inverter has a (A) suffix, that's means that the inverters come with the AFCI function, example:

PSI-X1P8000-TL [This does not have AFCI Function]

PSI-X1P8000-TL (A) [This have AFCI Function]

Always have this manual at hand in case you need it.

1. Safety Measures

1.1. General Notice

1. Contents may be periodically updated or revised. Peimar reserves the right to make improvements or changes to the product(s) and program(s) described in this manual without prior notice.
3. Installation, maintenance, and grid-related settings can only be performed by qualified personnel who:
 - Are licensed and/or comply with state and local jurisdiction regulations.
 - Have thorough knowledge of this manual and other related documents.
4. Before installing the device, carefully read, fully understand, and strictly follow the detailed instructions in the user manual and other related regulations. Peimar shall not be liable for any consequences caused by the violation of the storage, transportation, installation, and operation regulations specified in this document and the user manual.
5. Use insulated tools when installing the device. Personal protective equipment must be worn during installation, electrical connection, and maintenance.

6. For more information, please visit the Peimar website at <https://www.peimar.com/ww/home/products/>

1.4. Descriptions of Labels



CAUTION, RISK OF ELECTRIC SHOCK

This device is directly connected to the public electricity grid, therefore any work on the inverter must be carried out by qualified personnel.



DANGER TO LIFE due to high voltage!

Do not touch live parts for 5 minutes after disconnection from the power sources.



WARNING, DANGER!

The appliance is directly connected to electric generators and to the public electricity grid.



DANGER HOT PARTS

The elements inside the inverter reach high temperatures during operation. Do not touch the metal case when the inverter is active (risk of burns).



This device MUST NOT be disposed as a municipal waste.

Please refer to the "Disposal" chapter of this manual for proper management of the disposal of the inverter.

**WITHOUT TRANSFORMER**

This inverter does not have an isolation transformer.

**EARTHING**

The connection point of the protective conductor for earthing is indicated on the inverter.

**CE MARK**

Devices with the CE mark meet the essential requirements of the Low Voltage Directive and the Electromagnetic Compatibility Directive.

**NOTICE**

The table is only used for the description of symbols which may be used on the inverter. Please be subject to the actual symbols on the device.

1.3. Proper Usage

This series inverter are PV inverters which can convert the DC current of the PV generator into AC current and feed it into the public grid.

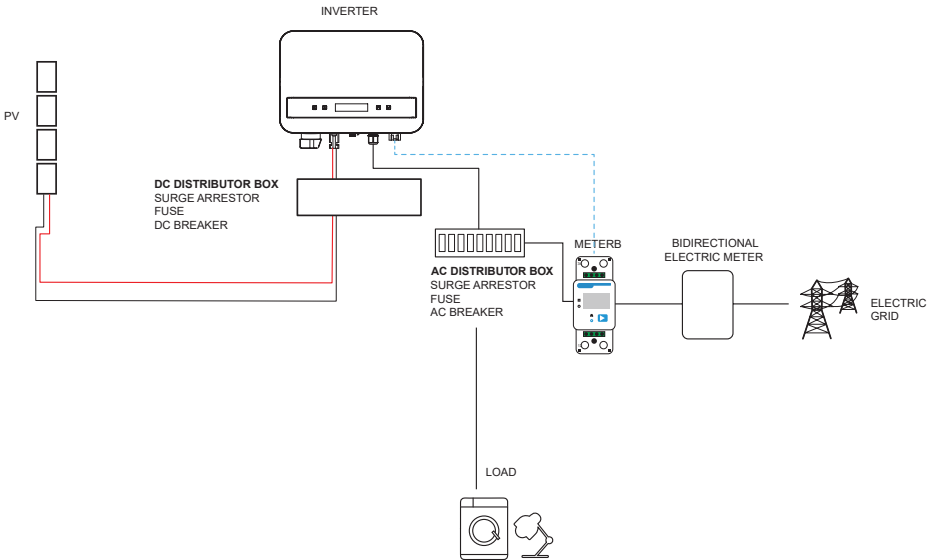

Lightning can cause damage either from a direct strike or from surges due to a nearby strike. Induced surges are the most likely cause of lightning damage in most situations or installations, especially in rural areas where electricity is usually provided by long overhead lines. Surges may affect both the PV array conduction and the AC cables leading to the building.

Specialists in lightning protection should be consulted during the end-use application. Using appropriate external lightning protection can mitigate the effects of a direct lightning strike on a building by controlling and discharging the lightning current into the ground.

All DC cables should be installed as short as possible, and positive and negative cables of the string or main DC supply should be bundled together. Avoid creating loops in the system. This requirement for short runs and bundling includes any associated earth bonding conductors. Spark gap devices are not suitable for use in DC circuits as once they conduct, they will not stop conducting until the voltage across their terminals drops below typically less than 30 volts

Anti-Islanding Effect:

The islanding effect is a special phenomenon where a grid-connected PV system continues to supply power to the nearby grid even when there is a voltage loss in the power system. This is dangerous for maintenance personnel and the public. This series of inverters provides Active protection to prevent the islanding effect.

1.3. Important safety instructions



DANGER!

- **Danger to life due to high voltages in the inverter!**
- All work must be carried out by a qualified electrician.
- The appliance should not be used by children or persons with reduced physical, sensory, or mental capabilities, or those lacking experience and knowledge, unless they have been given proper supervision or instruction.
- Children should be supervised to ensure that they do not play with the appliance.



CAUTION

- **Danger of burn injuries due to hot enclosure parts!**
- During operation, the upper lid of the enclosure and the enclosure body may become hot.
- Only a qualified electrician can touch the lower enclosure lid during operation



CAUTION

- Possible damage to health because of the effects of radiation!
- Pregnant women and children should not stay close to the inverter



WARNING!

- Grounding the PV generator!
- Comply with the local requirements for grounding the PV modules and the PV generator. We recommend connecting the generator frame and other electrically conductive surfaces in a manner that ensures continuous conduction and

grounding. This provides optimal protection for both the system and individuals. Only a qualified electrician can touch the lower enclosure lid during operation

**WARNING!**

-
- Ensure input DC voltage is \leq Max. DC voltage. Overvoltage may cause permanent damage to the inverter or other losses, which will not be covered under warranty!
 - Risk of electric shock!

**WARNING!**

-
- Authorized service personnel must disconnect both AC and DC power from the inverter before attempting any maintenance, cleaning, or working on any circuits connected to the inverter.
 - Prior to the application, please read this section carefully to ensure correct and safe application. Please keep the user manual properly.
 - Use only recommended attachments. Otherwise, there may be a risk of fire, electric shock, or injury to persons.
 - Make sure that existing wiring is in good condition and that the wire is not undersized.
 - Do not disassemble any parts of the inverter that are not mentioned in the installation guide. It contains no user-serviceable parts. See the warranty for instructions on obtaining service. Attempting to service the inverter yourself may result in a risk of electric shock or fire and will void your warranty.
 - Keep away from flammable and explosive materials to avoid fire disaster.
 - The installation place should be away from humid or corrosive substances.
 - Authorized service personnel must use insulated tools when installing or working with this equipment.
 - PV modules shall have an IEC 61730 class A rating.
 - Avoid touching the PV connecting device to prevent electric shock.
 - After the MAINS and PV supply has been disconnected, the capacitor of the unit still contains hazardous voltage for up to 5 minutes. Please do not touch during this period. Hazardous voltage will be present for up to 5 minutes after disconnection from the power supply.

**CAUTION - RISK of electric**

Shock from energy stored in the capacitor. Never operate on the solar inverter couplers, the MAINS cables, PV cables, or the PV generator when power is applied. After switching off the PV and Mains, always wait for 5 minutes to let the intermediate circuit capacitors discharge before you unplug DC and MAINS couplers.

When accessing the internal circuit of the solar inverter, it is very important to wait 5 minutes before operating the power circuit or demounting the electrolyte capacitors inside the device. Do not open the device beforehand since the capacitors require time to sufficiently discharge!

Measure the voltage between terminals UDC+ and UDC- with a multimeter (impedance at least 1 Mohm) to ensure that the device has totally discharged.

1.5. PE Connection and leakage Current

The inverter incorporates a certified internal Residual Current Device (RCD) in order to protect against possible electrocution and fire hazards in case of a malfunction in the cables or the inverter. There are two trip thresholds for the RCD as required for certification (IEC 62109-2: 2011). The default value for electrocution protection is 30 mA, and for slow-rising current is 300 mA.

If an external RCD is required by local regulations, check which type of RCD is needed according to the relevant electric code. It is recommended to use a type-A RCD. The recommended RCD value is 300 mA unless a lower value is required by specific local electric codes.

The device is intended to connect to a PV generator with a capacitance limit of approximately 700 nF.

**WARNING**

- High leakage current!
- Earth connection is essential before connecting power supply.

2. Product Information

2.1. Basic Features

The inverter incorporates advanced technology, high reliability, and convenient control features:

- Advanced DSP control technology.
- Utilize the latest high-efficiency power component.
- Optimal MPPT technology.
- Three MPP Tracking.
- Wide MPPT input range.
- Advanced anti-islanding solutions.
- Class I protection level.
- Max. efficiency up to 98.2%. EU efficiency up to 97.5%.
- THD<3%.

2.2. Product Model Specifications PSI-X1PXXXX-TLS (A):

- PSI-X1P indicates the series name of the inverter.
- XXXX indicates the nominal power in watts (W) of the inverter.
- TLS indicates that it is a transformerless inverter with a Triple MPPT.

2.3. Product Dimension

The PSI-X1Sxxxx-TL series grid inverters have the dimensions shown in the following figure:

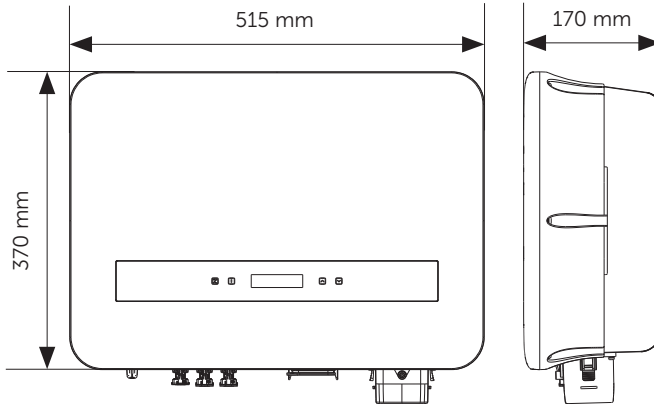

2.4. Component List

Item No.	Item Name	Quantity
/	Inverter	1 pc
/	Bracket	1 pc
A	Expansion tube	3 pcs
B	Self-tapping screw	3 pc
C	Washer	3 pcs
D	M5 screw	1 pc
E	R-type terminal for PE connection	2 pcs
F	RJ45 terminal	2 pcs
G	Positive PV connector	2 pairs for inverters with two inputs of MPPT
H	Positive PV pin contact	3 pairs for inverters with three inputs of MPPT
I	Negative PV connector	2 pairs for inverters with two inputs of MPPT
J	Negative PV pin contact	3 pairs for inverters with three inputs of MPPT

K	Positive PV dustproof buckle	1 pair for inverters with two inputs of MPPT
L	Negative PV dustproof buckle	2 pairs for inverters with three inputs of MPPT
M	Disassembling tool for PV terminal	1 pc
N	Spacer for AC connection	2 pcs
O	R-type terminal for AC connection	3 pcs
P	AC waterproof cover	1 pc
Q	Sealing ring	1 pc
R	Communication connector	1 pc
S	Cord and terminal	20 pcs
T	Documents	/
U	RJ45 coupler (Optional)	1 pc
/	Dongle (Optional)	/



NOTICE

Consult the list of accessory parts contained in the packaging and verify that they are all present before installing. If any parts are missing, contact your dealer as soon as possible. Please keep the original packaging in case you need to return the product for repair or replacement. *Dongle is included from inverter of 2 kW and above.

2.5. Terminals of the Inverter

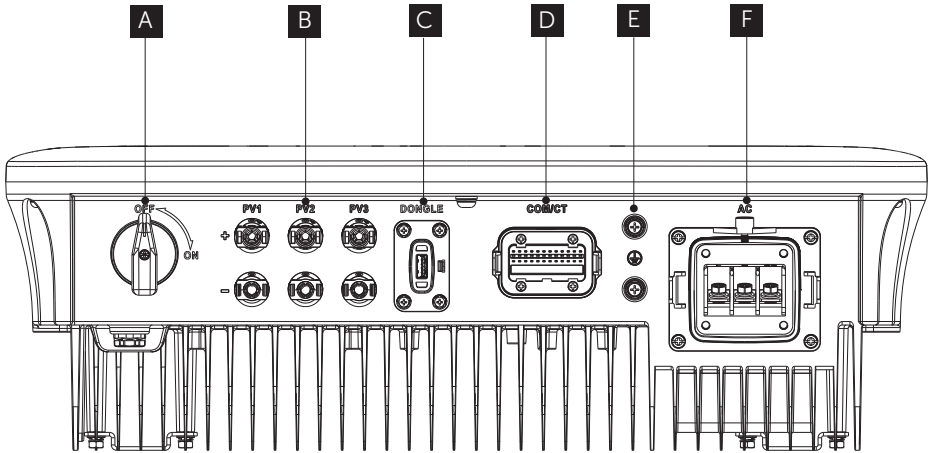

Part	Description
A	DC Switch
B	PV connection port (PV1, PV2 and PV3 for inverters with three inputs of MPPT; PV2 and PV3 for inverters with two inputs of MPPT)
C	Monitoring connection / Upgrade port
D	COM/CT port
E	AC output Terminal
F	Ground Terminal
E	Ground connection port
F	AC connection port

3. Installation instructions

3.1. Installation Precaution



WARNING!

- Danger to life due to risk of fire or electric shock.
- Do not install the inverter near flammable or explosive objects.
- This inverter will connect directly to a HIGH VOLTAGE electrical generator. Installation should be carried out only by qualified and trained personnel with experience.



NOTICE

- This appliance complies with environmental pollution degree II for outdoors.
- An inappropriate or non-compliant installation environment may compromise the useful life of the inverter.
- It is not recommended to install the inverter in direct sunlight.
- The installation site must be well ventilated.
- Please avoid direct sunlight, rain exposure, snow laying up during installing and operating.

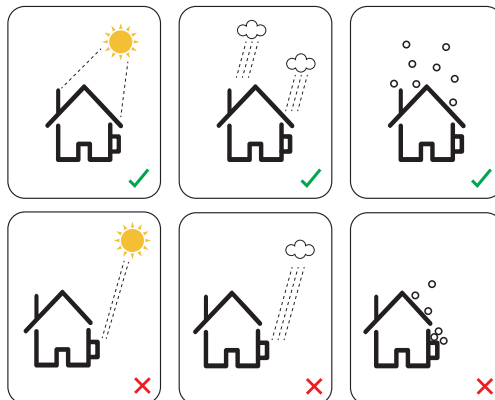

3.2. Packaging Control

Although Peimar inverters have undergone rigorous checks and tests before leaving the factory, damage during transport cannot be ruled out. Check the packaging for obvious damage, if so, do not open the box and contact your dealer as soon as possible.

3.2. Installation and placement procedure

The device is cooled by natural convection and can be installed indoors or outdoors. Do not expose the inverter to direct sunlight, as the power may be reduced due to overheating. Do not expose the inverter to rain or snow, as this may affect its service life.

1. Install the appliance as shown in the figure below. We recommend vertical installation or with a maximum inclination of 5° backwards. Never install the inverter tilted forward or sideways, horizontally or upside down.

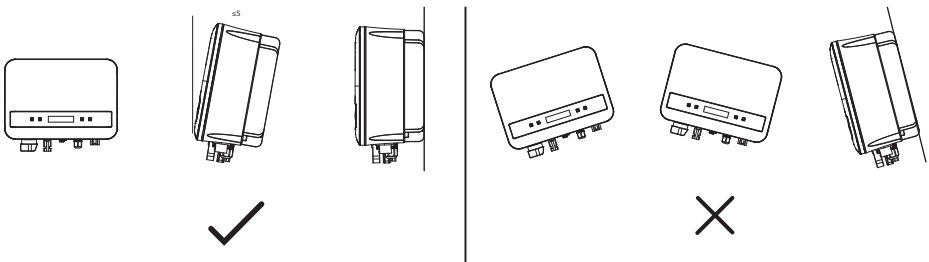

1. Install the inverter at eye level for easy viewing of the screen and possible maintenance.
2. Install the inverter in such a way that it can be dismantled for maintenance work. Make sure there is minimum free space around the appliance to ensure ventilation, as shown in the figure below.

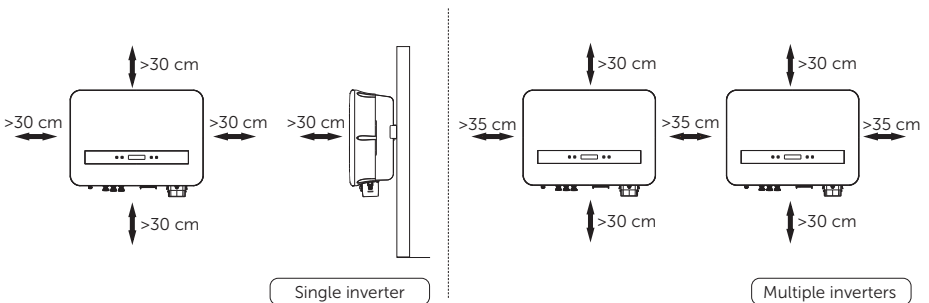

3.5. Mounting procedure

- 1 Use the wall bracket as a template to mark the position of the 3 holes on the wall.

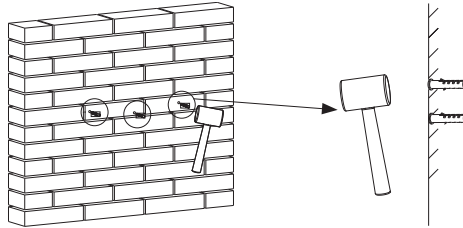

- 2 Drill holes with the drill (Ø10 drill.), make sure the holes are deep enough (at least 60 mm) for the installation.

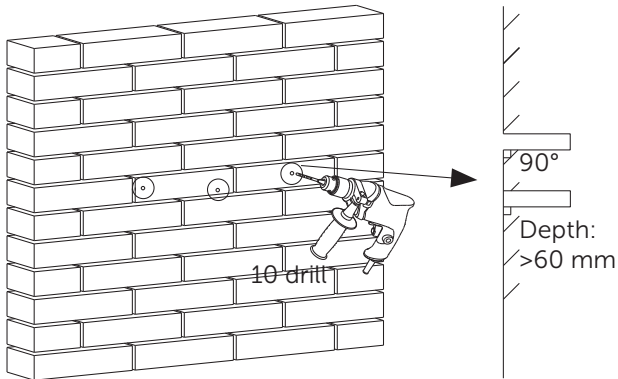

- 3 Insert the expansion tubes (part B) in the holes using the mallet, place the wall bracket and use self-tapping screws (part A) to tighten the bracket.
- 4 Hang the inverter over the bracket, move the inverter close to it, slightly lay down the inverter, and make sure the mounting bar on the back are fixed well with the groove on the bracket.

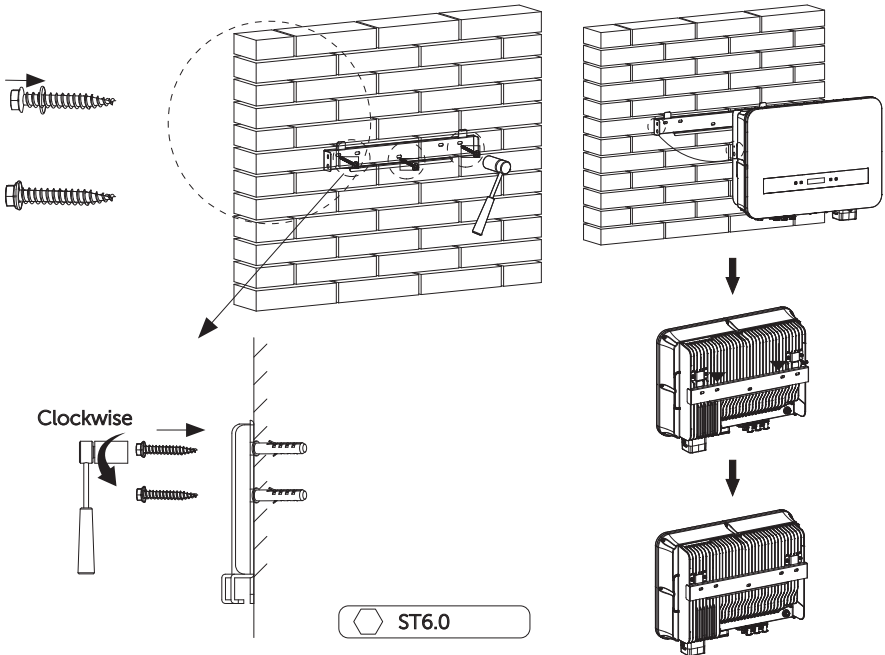

- 5 Screw down the M5*L8 (part D) screw on the left side of the inverter.

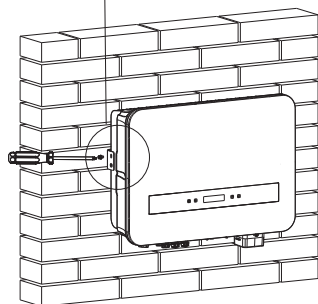
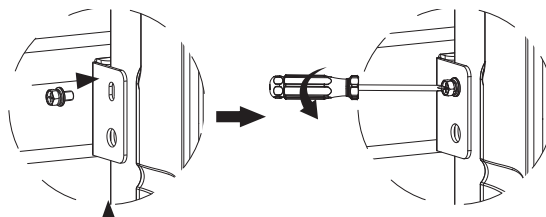

+	M5
⌚	1.2±0.1 N·m

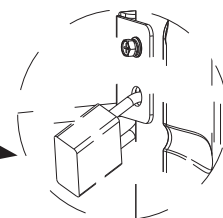
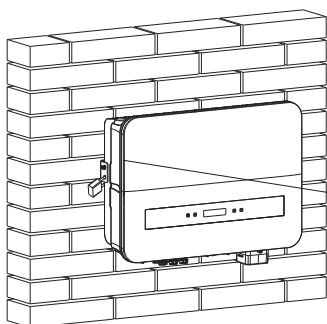

Lock (Prepared by yourself)

3.6. Connections of the Inverter

A. PV String Connection (PV Array to Inverter)

The inverter has a three-string PV connector. Please select PV modules with excellent functionality and reliable quality. The open-circuit voltage of the connected module array should be less than the Max. DC input voltage (as shown in the table below), and the operating voltage should be within the MPPT voltage range.

Model	PSI-X1P-8000-TLS (A) PSI-X1P-10000-TLS (A)
Max. DC Voltage (V)	600.00



DANGER!

- When exposed to sunlight, the PV array produces dangerous DC voltage that is present in the DC conductors. Contact with these conductors can result in deadly electric shocks.
- Ensure the PV modules are covered.
- Avoid touching the DC conductors



WARNING!

- The voltage of PV modules is very high and falls within the dangerous voltage range. Please comply with electrical safety rules when making connections.
- Please do not ground the PV positive or negative!
- Please follow the requirements of PV modules as below:
 - A. Same type; Same quantity; Identical alignment; Identical tilt.
 - B. To save cable and reduce DC losses, we recommend installing the inverter close to the PV modules.



PLEASE NOTE

- Copper cable is recommended. If you use aluminum cable, please consult the inverter manufacturer.
- Parameters may vary due to different environments and materials. The cross-sectional area of the PE line should match that of the L/N line. Please choose appropriate cables and micro-breakers in accordance with local laws and regulations.
- Tools needed:

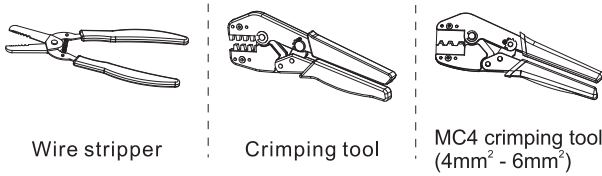

1. Turn off the DC switch, then choose 4mm² wire to connect the PV module.
2. Strip 7mm of insulation from the wire end by using the wire stripper crimping tool.

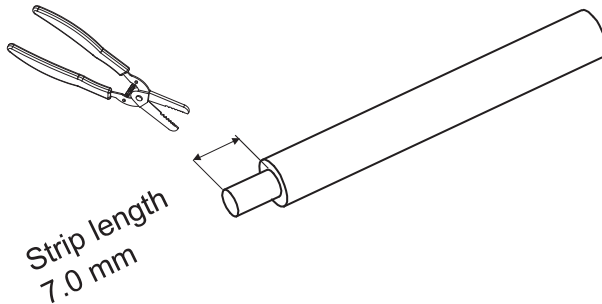

3. Insert striped wire into pin contact and ensure all conductor strands are captured in the pin contact.

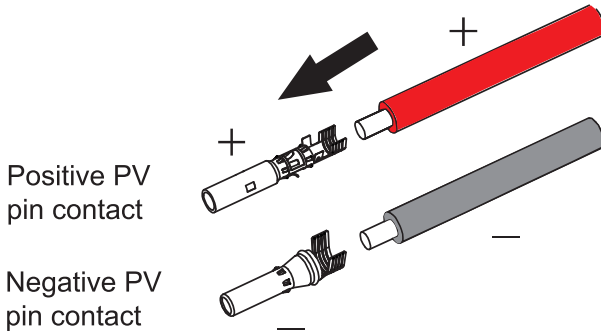

4. Crimp pin contact by using the MC4 crimping tool.

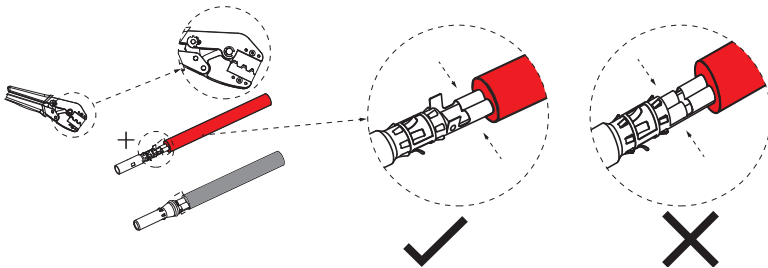

5. Separate the DC connector into two parts: the plug and the cable nut. Insert the wire into the plug firmly. When a "click" is heard or felt, the pin contact assembly is correctly seated.

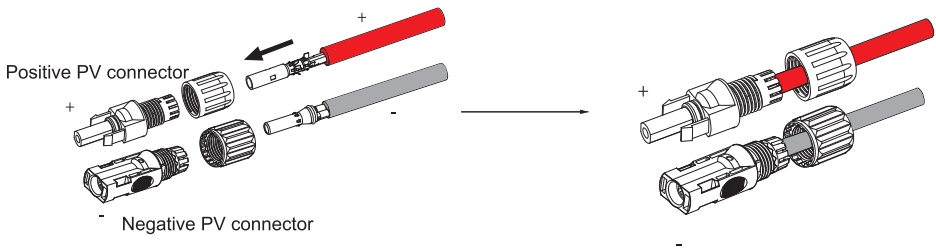

6. Then screw down the cable nut.

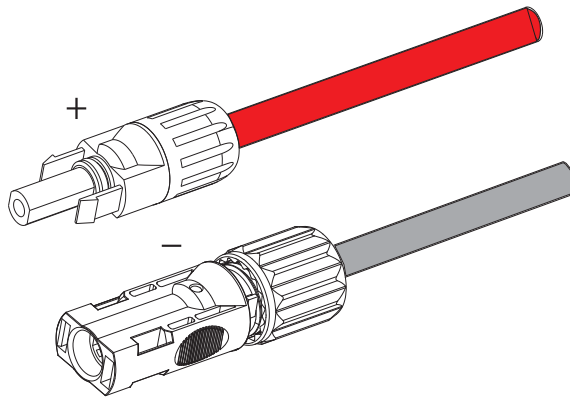

7. Use a multimeter to check the open-circuit voltage between the positive and negative poles of the PV cable. Ensure that the open-circuit voltage is below the maximum allowable input voltage; otherwise, the equipment may be damaged.
8. Take off the blue protective cover from the PV positive & negative terminals at the bottom of the inverter and insert the prepared PV terminals coming from the PV array, ensuring the positive and negative terminals match correctly.



NOTICE

Keep the DC switch of the inverter OFF during connection!

If is needed to disassemble the PV Cables follow the next steps in the image.

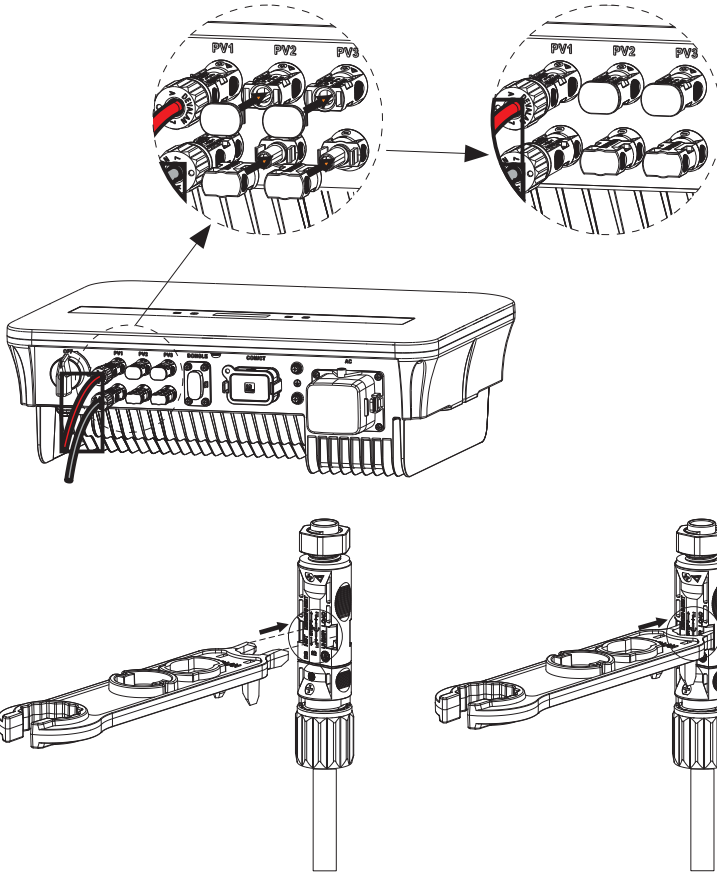

B. CA Connection (Inverter to Grid)

The inverter is designed for single phase grid. Voltage range is 220/230/ 240 V, frequency is 50/ 60 Hz. Other technical requests should comply with the requirement of the local public grid.



PLEASE NOTE

Breaker/Micro-breaker should be installed between inverter and grid, any loads should not be connected with inverter directly.

Connection Steps:

1. Fetch the AC waterproof cover from accessory bag. Take out the sealing ring 1 from inside the cover, loosen the swivel nut from the cover, and disassemble it as shown below.

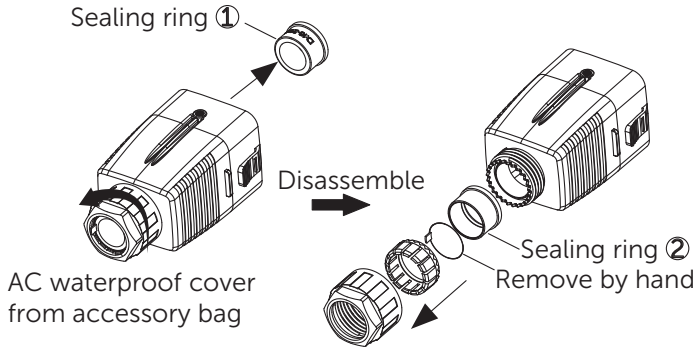

2. Select appropriate sealing ring according to the outer diameter of the prepared AC cable. Thread the AC cable as shown below.

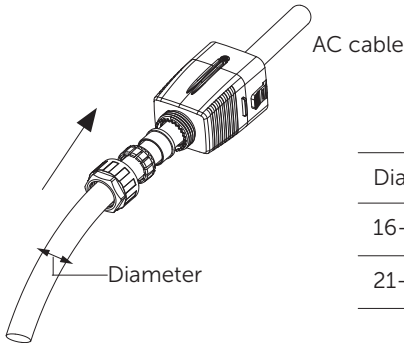

Diameter (mm)	Sealing ring
16-21	①
21-24	②

- Strip the insulation jacket of L, N and PE wires of the AC cable by wire stripper as below. Then pull the heat shrink tubing over the wires and insert the stripped sections into the R-type terminals for AC connection.

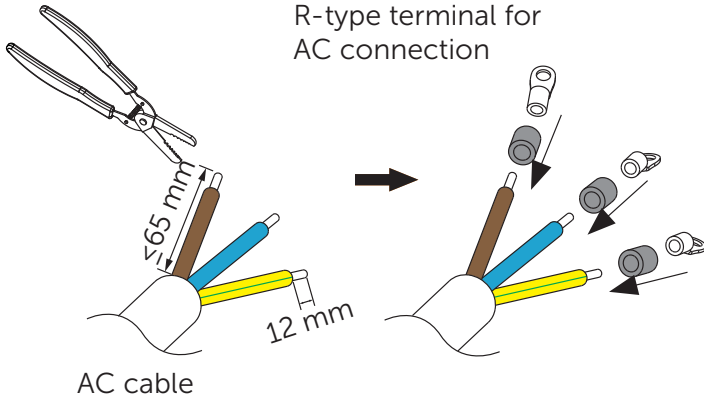

- Crimp the terminals with crimping tool for R-type terminal, pull the heat shrink tubing over the crimped sections of the R-type terminals for AC connection and use a heat gun to shrink it so that it can be firmly contacted with the terminals.

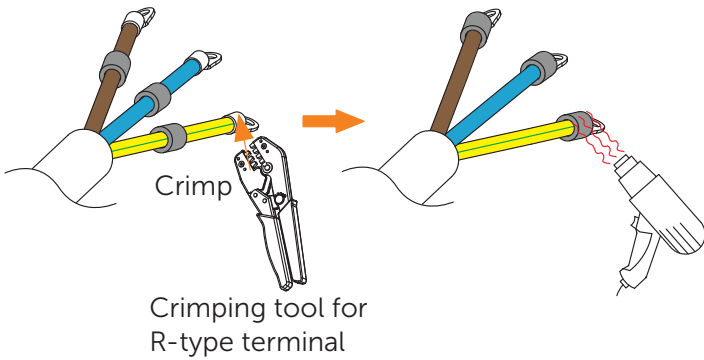

5. Remove the dust cover from AC connection port.

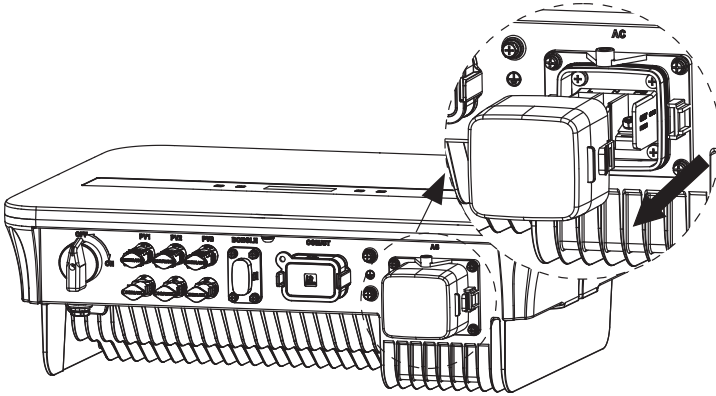

6. Install the two spacers for AC connection on the inverter as shown below.

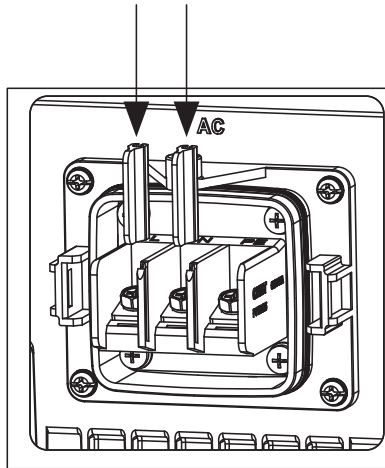

7. Take down the screws on the AC connection port of the inverter.

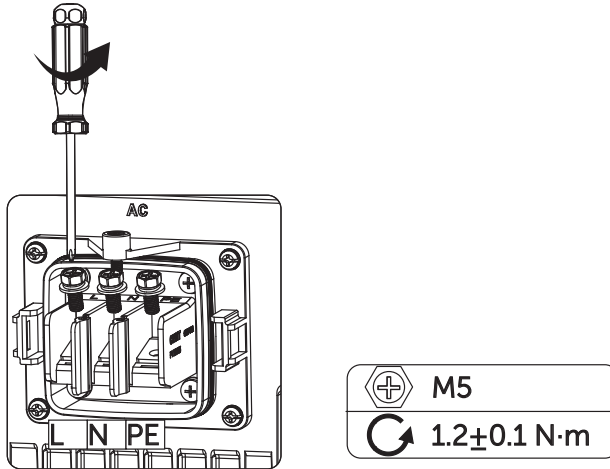

8. Connect the L, N and PE wires to the inverter and align the screws, please note to keep the side of the AC waterproof cover shown below outwards.

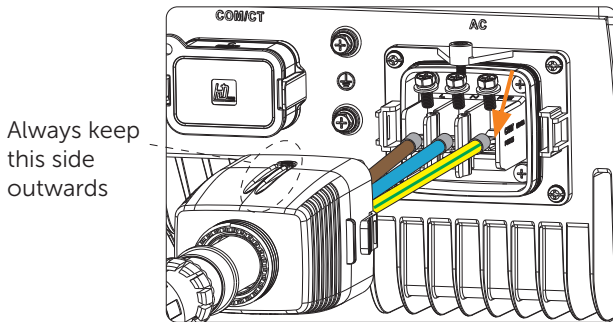

9. Tighten the screws to secure the wires.

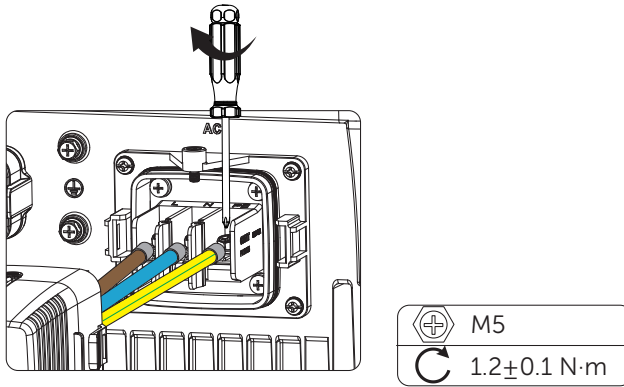

10. Align the AC waterproof cover with the AC connection port of the inverter, a "click" sound will be heard when the cover is correctly seated.

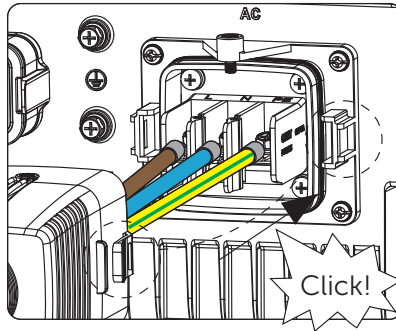

11. Fasten the swivel nut of the AC waterproof cover and use a cross screwdriver to secure the cover.

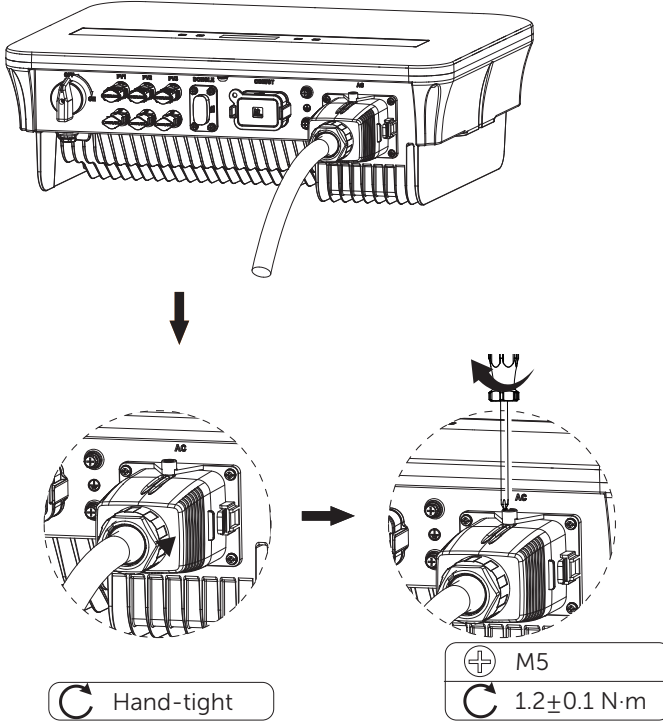

C. Earth Binding

Screw the ground screw with cross screwdriver shown as follow.

(torque: $1.5 \pm 0.2 \text{ N}\cdot\text{m}$).



WARNING!

Be sure the ground wire must be connected!

Connection steps:

1. Use a crimping tool to strip the terminal (part C) from the PE cable.

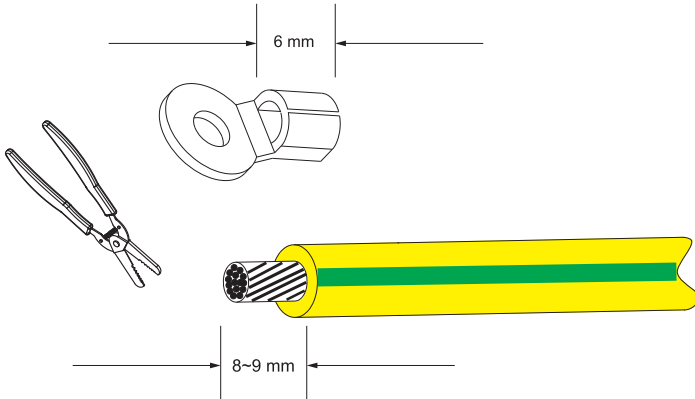

2. Slide the heat-shrink tubing over the PE cable, inset the PE cable into the terminal.

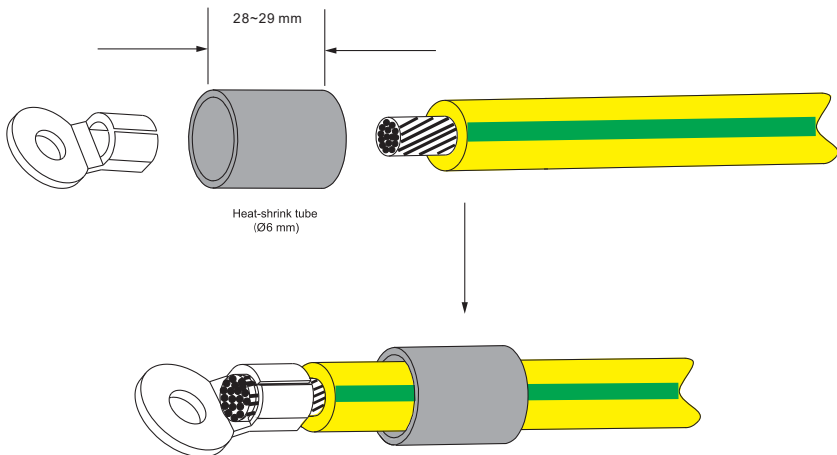

3. Use a crimping tool to squish the terminal.

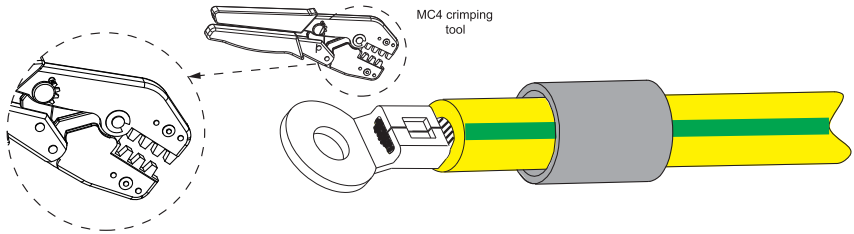

4. Use a hot-air blower to blow the heat-shrink tubing.

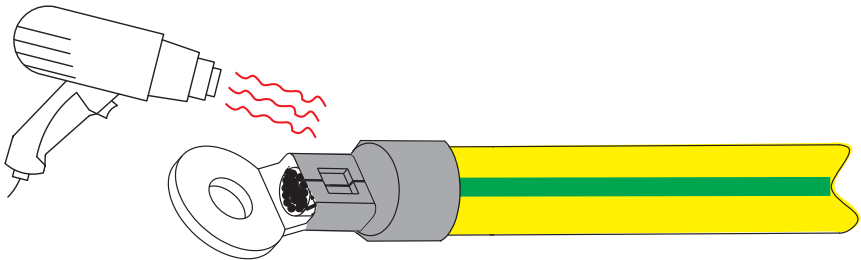

5. Connect the PE line with inverter

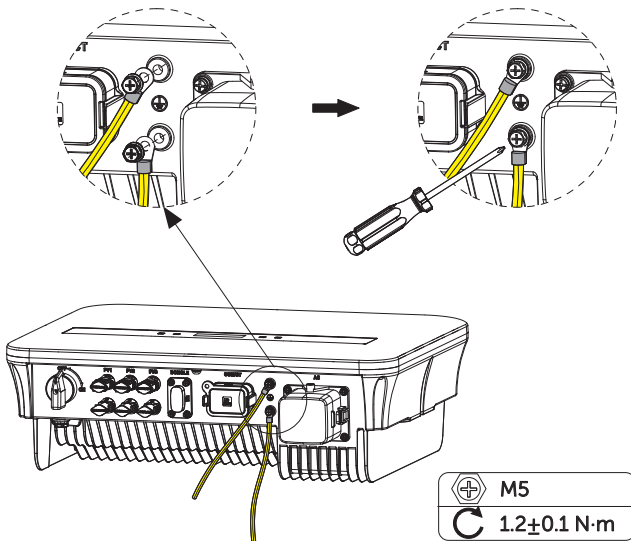

D. Communication Interface

This product includes a range of communication interfaces, such as WiFi, COM/CT, and USB, to facilitate human-machine interaction and upgrades. Operating data, including output voltage, current, frequency, and fault information, can be downloaded to a PC or other monitoring devices through these interfaces.

This inverter provides a DONGLE port which can collect information from inverter including status, performance and updating information to monitoring website via connecting Wi-Fi dongle (optional, purchase the product from supplier if needed)

For the Dongle Port follow this connection steps:

1. Plug the WiFi Dongle into "DONGLE" port at the bottom of inverter.
2. Connect the WiFi with router.
3. Scan below QR code or search for the keyword "Monitoring Cloud" in APP Store to download the corresponding APP for setting up the monitoring.
4. Follow the steps to create a new account, set up internet connections and check the inverter status. (For more details of the monitoring configuration, please refer to the WiFi/LAN/4G Dongle user manual in the box).

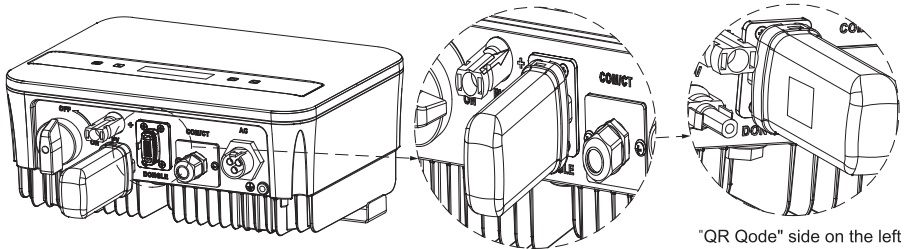

RS485 is a standard communication interface that can transmit real-time data from the inverter to a PC or other monitoring devices.

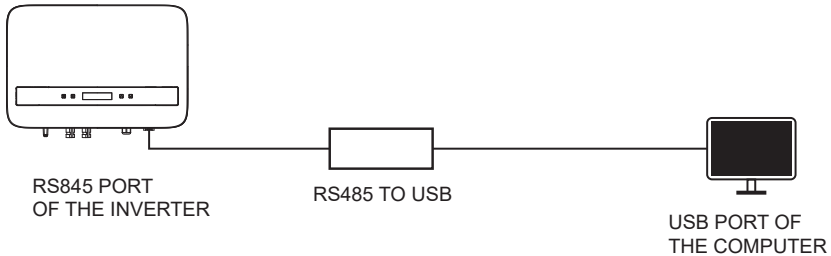

For the COM/CT Port follow this connection steps:

1. Fetch the communication connector from the accessory bag, and disassemble it. Loosen the swivel nut from the communication connector. a. Loosen the swivel nut from the communication connector.

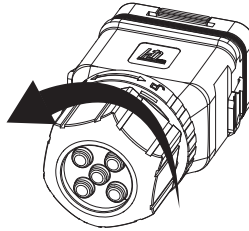

- b. Take out the stopper and press the part as shown below on both sides and pull the terminal block out.

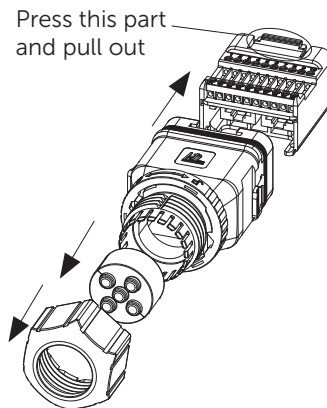

- c. Remove the waterproof plugs based on actual needs.

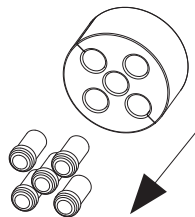

Pin Definitions

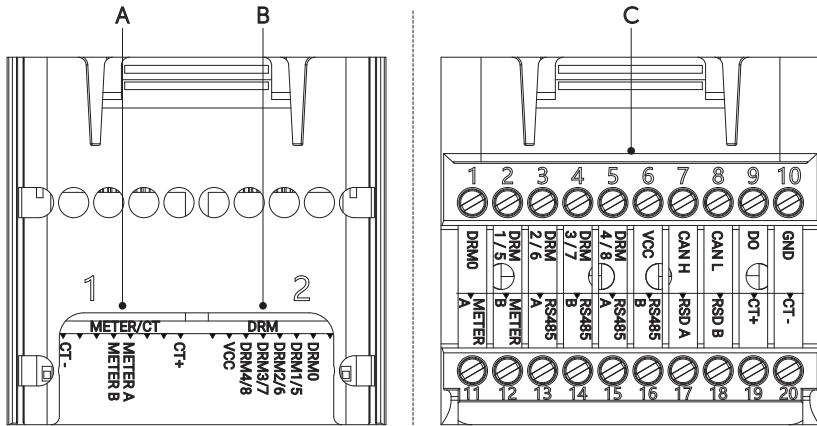

Pin	1	2	3	4	5	6	7	8
Pin Definition	CT+	X	X	Meter A	Meter B	X	X	CT-

Table 7-2 Pin Definition of Section B (DRM)

Pin	1	2	3	4	5	6	7	8
Pin Definition	X	DRM0	DRM1/5	DRM 2/6	DRM 3/7	DRM 4/8	VCC	X

Table 7-3 Pin Definition of Section C

Pin	Pin Definition	Pin	Pin Definition
1	DRM0	11	METER A
2	DRM1/5	12	METER B
3	DRM 2/6	13	RS485 A
4	DRM 3/7	14	RS485 B
5	DRM 4/8	15	RS485 A
6	VCC	16	RS485 B
7	CAN H	17	RSD A
8	CAN L	18	RSD B
9	DO	19	CT+
10	GND	20	CT-

2. Prepare and make the communication cable(s) according to the actual application scene.



NOTICE

- When connecting with meter or CT, users can connect via either section A (recommended) or section C.
 - When connecting with DRM, users can connect via either section B (recommended) or section C. For DRM, only DRM 0 is available now.
- a. Thread the communication cable (network cable CAT5) through the swivel nut, the stopper, and the communication connector.

If the communication cable is without RJ45 terminal, thread the cable through whichever hole of the stopper and strip 15 mm of the insulation jacket. Then insert the stripped part into the RJ45 terminal (part F) and crimp it with a crimping tool for RJ45.

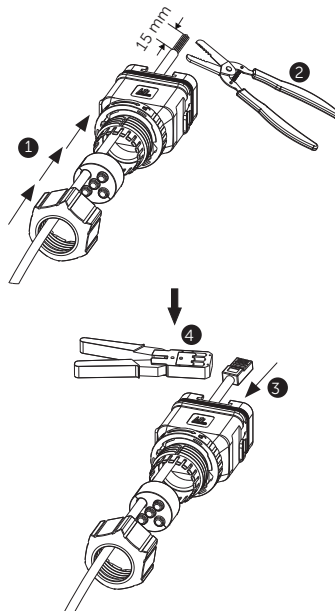

If the communication cable is with RJ45 terminal, thread the cable through one of the holes with an opening of the stopper.

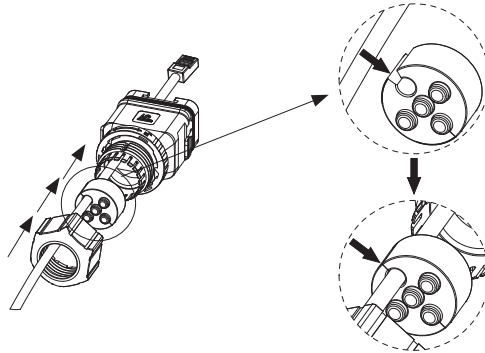

- b. Insert the RJ45 terminal to section A or B of the terminal block according to actual application.

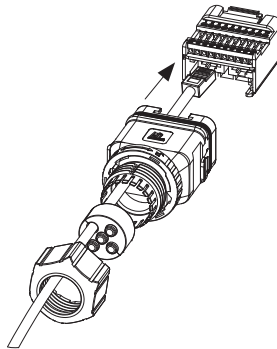

- c. Pull the terminal block back to the connector until a "click" sound is heard. Then pull the stopper and the swivel nut back.

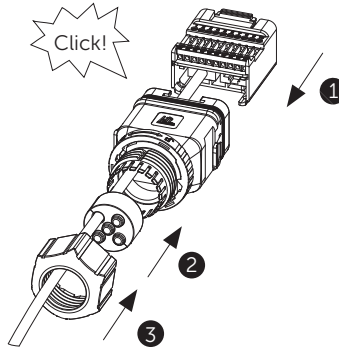

- d. Tighten the swivel nut until a "click" sound is heard, at which time the lock of the communication connector will be locked automatically.

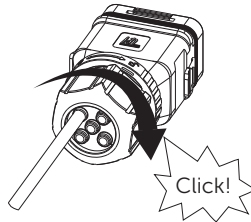

 Hand-tight

If connect via section C (Use two-core cable), follow the next steps:

- a. Strip the two-core communication cable as shown below according to the actual application.

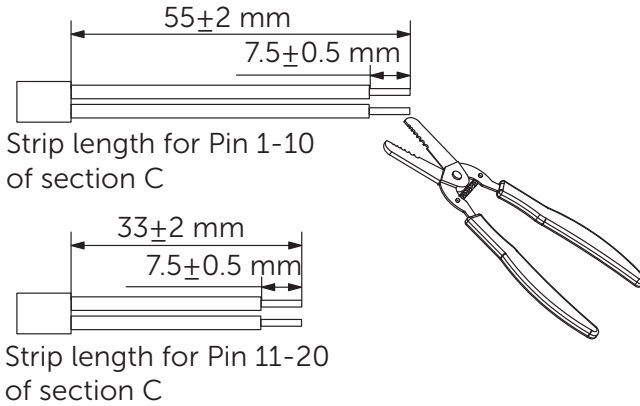

- b. Put the cord end terminals (part S) on the stripped parts of the cable end and use a crimping plier to ensure the wires are securely in place.

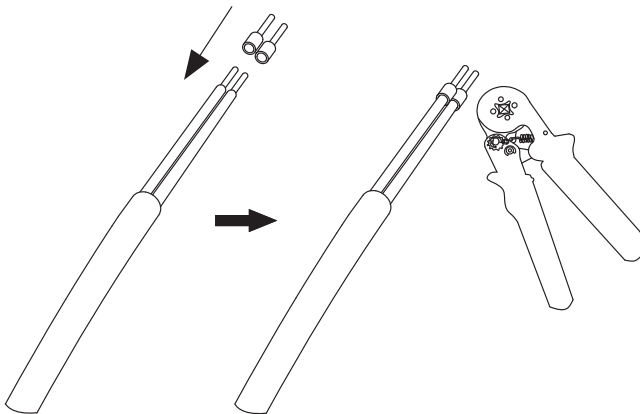

- c. Insert the crimped parts to the correct pins following the pin definitions.

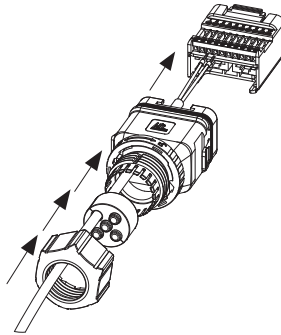

- d. Secure the screws with a flat-head screwdriver.

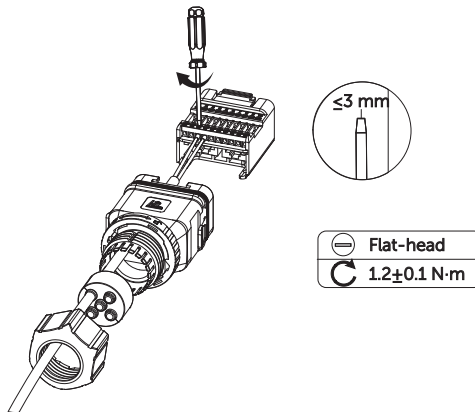

- e. Pull the terminal block back to the connector until a "click" sound is heard. Then pull the stopper and the swivel nut back.

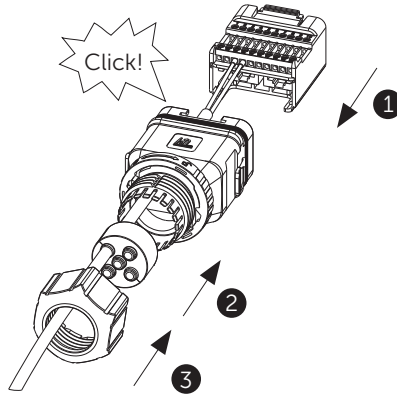

- f. Tighten the swivel nut until a "click" sound is heard, at which time the lock of the communication connector is locked automatically.

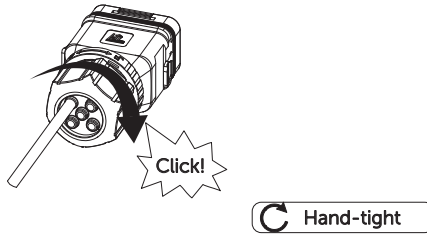

NOTICE

If the communication connector needs to be re-disassembled, please turn the lock in the middle part of the connector to the right side with one hand and maintain the force while rotating the swivel nut anti-clockwise with the other hand at the same time.

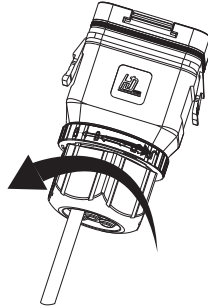

3. Connect the communication connector to the inverter.
 - a. Remove the dust cover from the COM/CT port of the inverter.

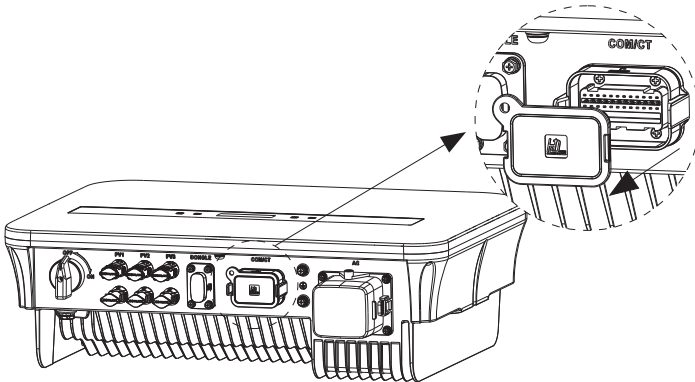

- b. Connect the communication connector to the inverter. Please note to keep the side shown as below outwards, and press the two parts when aligning to the COM/CT port of the inverter.

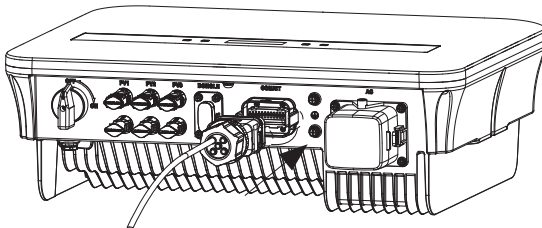

Note:

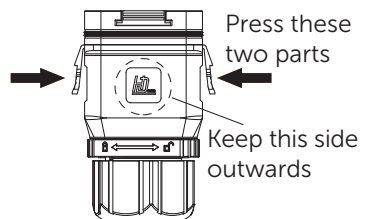

- c. It is well connected when a "click" sound is heard.

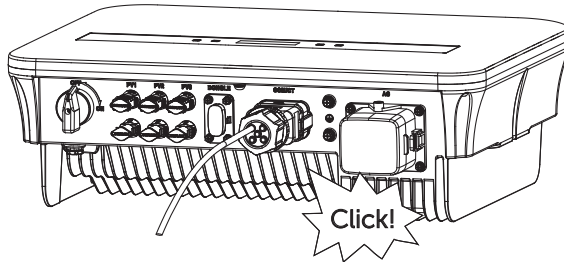

E. Meter Connection (Optional)

The meter is a device that allows you to analyze the energy flow of the installation to manage it in the most appropriate way. The meter compatible with single-phase inverters. For the meter the maximum current is 80 A and is configured with direct connection PSI-X-1PMETER-ZI. Therefore, the installation of the PSI-X-1PMETER-ZI meter allows:

- Monitor self-consumption during daylight hours on the inverter screen or on the monitoring portal.
- Read consumption in real time on the meter screen.

Configure the power "Export Limit" function which, if activated, allows the system to block the injection of excess energy into the grid. If the "Export Limit" function is disabled (default value), the energy not self-consumed by the connected devices will be injected into the network.

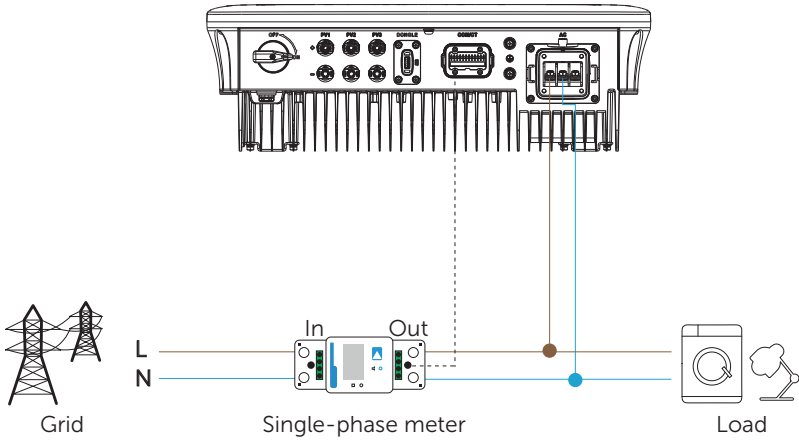

For connection the PSI-X-1PMETER-ZI follow the next indications:



WARNING!

Make sure the AC side power supply is disconnected at the installation line.

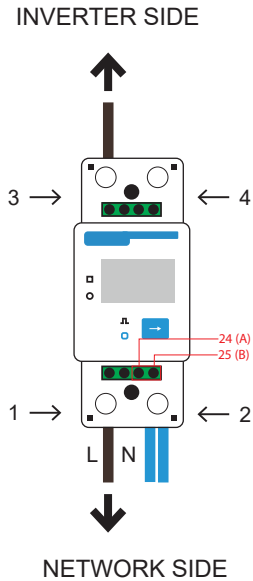

- 1 & 3 Are the Line terminals
 - 2 & 4 Are the Neutral terminals
 - 24 & 25 are the communication terminals
1. Strip the incoming phase (L) of the meter(mains side) by 8 to 10 mm and fix it to input 1 of the meter by tightening the clamp.
 2. Strip the incoming phase (L) of the installation (inverter side) from 8 to 10 mm and fix it to input 3 of the meter.
 3. Strip the incoming neutral (N) of the meter and the installation (inverter side) from 8 to 10 mm and fix it to input 2 of the meter by tightening the clamp. It is also possible to connect the incoming neutral of the installation (inverter side) to output 4 of the meter.



PLEASE NOTE

The communication cables to connect the meter must have a section $\leq 16.00 \text{ mm}^2$ and a minimum section of 1.00 mm^2 .

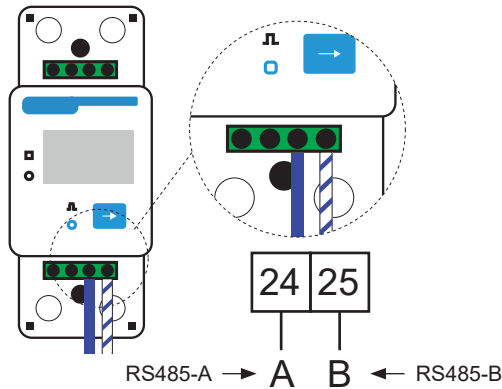

5. Provide a twisted pair cable of sufficient length to cover the distance between the inverter and the meter. Failing that, provide an RS485 cable of adequate length. Strip the two wires from a terminal, insert them into outputs 24 (A) and 25 (B) of the counter and secure them by tightening the clamp.
9. For the PSI-X-1PMETER-ZI meter to function correctly, the correct setting must be selected on the PSI-1XS grid inverter. On the screen, go to the menu and select Counter:

MENU > OPTIONS > Password «2014» > Export Control > Mode Select > Meter > Activate.



PLEASE NOTE

To activate the export limit function and ensure that no power is exported to the grid, activate the corresponding option in the advanced settings of the inverter. From the screen, go to the menu:

MENU > OPTIONS > Password «2014» > Export Control > Select Mode > Counter > 0W.

10. The display of the PSI-X-1PMETER-ZI counter turns on as soon as power is supplied to the system. The counter is now automatically set to the correct network parameters. By briefly pressing the "arrow" button it is possible to scroll through the different adjusted parameters and check them. The counter is already preset with the correct operating parameters, so there is no need to modify them.

Once the electrical connection has been made, fix the PSI-X-1PMETER-ZI meter on DIN rails (35 mm high). Since the meter is not waterproof or dustproof, it is recommended to install it inside the distribution cabinet.

F. Application of PSI-X-HPAB-S

With the Peimar PSI-X-HPAB-S (Adapter Box), users can effectively utilize solar energy by commanding it to power their heat pump using settings available on the Peimar inverter and Peimar X Portal. This intelligent integration allows for optimized solar self-consumption and ultimately helps in reducing electricity bills.

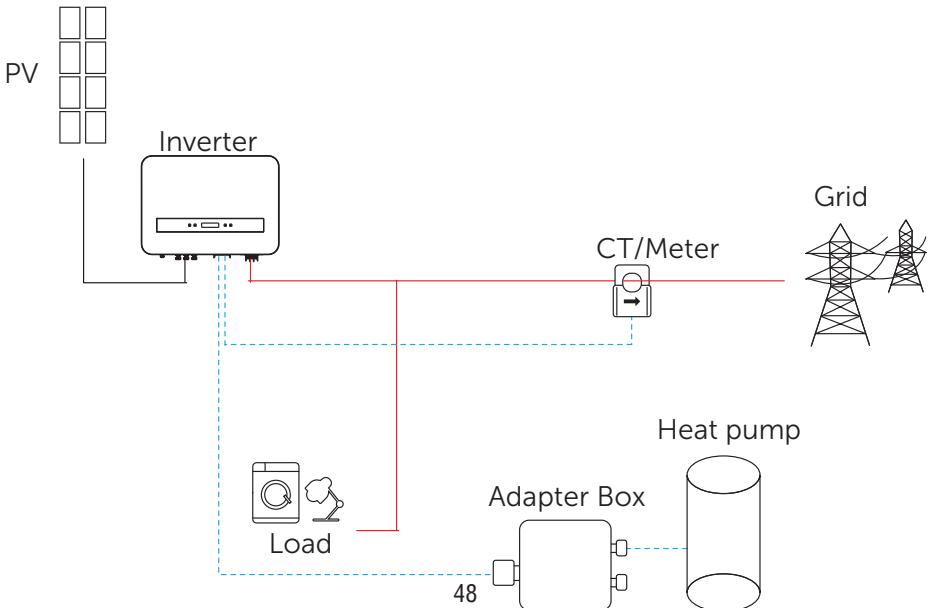

The inverter communicates with Adapter Box G2 via RS485. In case of excess power, the Adapter Box G2 can utilize it to heat the pump through the connection of dry contacts, SG Ready, or Analog output between the Adapter Box G2 and the heat pump. To power the Adapter Box G2, an external power adapter is required as the inverter itself cannot supply power to the Adapter Box G2.

Connection with Inverter:

Section C of COM/CT	Port of the inverter	RS485-inv port of Adapter Box G2	
Pin	Pin definition	Pin	Oin Definition
13/15	RS485A	4	RS485-A
14-16	RS485B	5	RS485-B

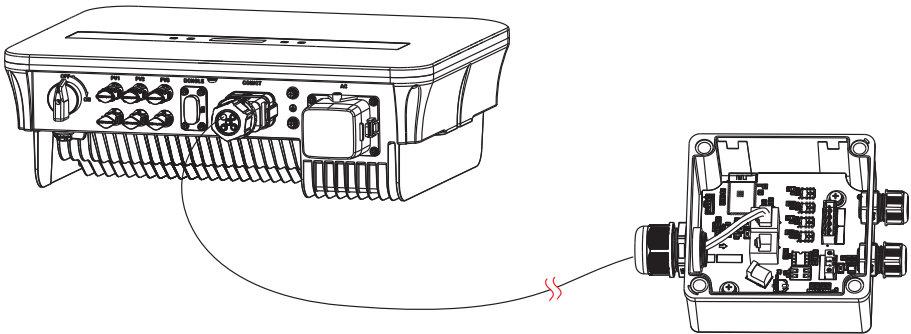

PLEASE NOTE

The communication cable between Adapter Box G2 and the inverter can not exceed 100 m.

Settings of PSI-X-HPAB-S

- a. Select Settings > Export Control > Mode Select > Meter / CT according to the actual application.
- b. Select Settings > Adapter Box G2 > Mode Select > Enable.

G. EV – Charger (Optional)

The inverter can communicate with the smart EV-Charger to form an intelligent photovoltaic, storage and EV charging energy system, thus maximizing the utilization of photovoltaic energy.

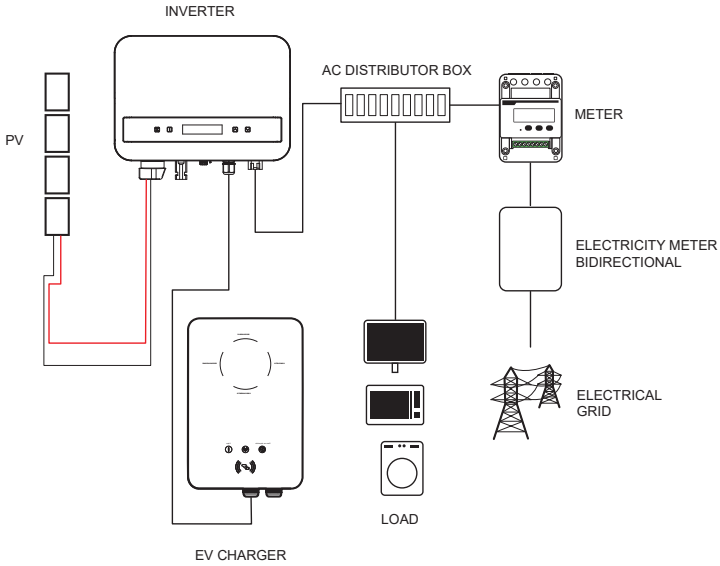

Wiring E-V Charger:

1. Plug one terminal of the communication cable to the right pin of the EVCharger and the other terminal to PIN 4 & 5 of the "COM/CT" port of the inverter.
2. Connect the meter to PIN 4 & 5 of the "COM/CT" port of the inverter.

Setting E-V Charger:

Turn on the power of the entire system, enter the "Settings" page of the inverters on the LCD screen.

1. Enter the "Export Control" page and chose "CT" or "Meter".

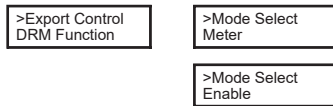

2. Select "EvChargerEnable" and then enter "Mode Select". Ensure the interface shows "Enable" under "Mode Select", which indicates the EVCharger function started successfully.

>EvChargerEnable Adapter Box

>Mode Select Enable

For the installation and settings of the EV-Charger, please refer to the user manual of the EV-Charger for details.



PLEASE NOTE

The EV-Charger function and the parallel system with Datahub or the parallel system with Modbus Function cannot be used at the same time currently.

4. Commissioning

1. Make sure the inverter is fixed to the wall.
2. Make sure the inverter is properly grounded.
3. Check that the DC and AC lines are connected correctly.
4. Make sure the meter, if any, is properly connected and in the correct position (upstream of all loads).
5. Set the DC disconnecter of the inverter to On.
6. Raise the AC line switch and DC line switches, if any.

If the electrical connections have been made correctly, the inverter display will illuminate when power is supplied to the installation. After a few seconds in which the inverter is in a control state, the installation will begin to function normally and produce electrical energy.

5. Parallel Connection

This series of inverters offers a parallel connection function, allowing multiple inverters to be connected in parallel within a single system. With a meter installed in the main circuit, it can control zero injection to the grid. The parallel system can be configured using the Modbus function.

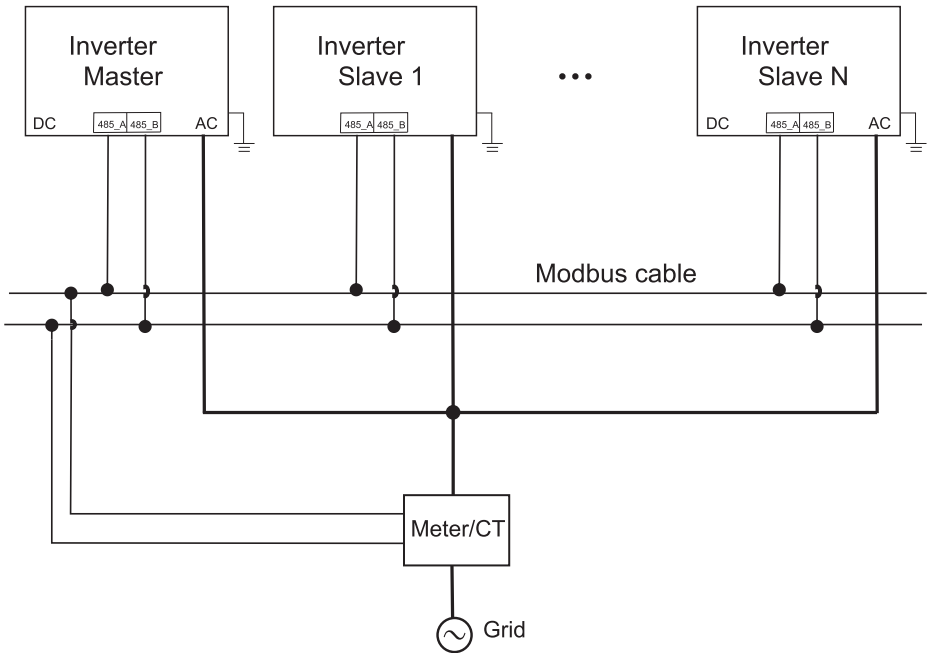

PLEASE NOTE

Before operation, please make sure that the inverters meet the following condition:

1. All the inverters shall be the same series
2. The firmware version of all inverters shall be the same otherwise, the parallel function cannot be used.

In this parallel system, at most 5 inverters can be connected. One inverter will be set as a master, and the rest are the slaves. The master inverter can communicate with all the slave inverters.

Wiring Operation:

- 1) Interconnect all inverters in the parallel system using RS485 cables.
- 2) Attach the communication cable to the master inverter.

Setting:

Power on the entire system and access the settings page of the inverters via the LCD screen. Follow the instructions below to complete the configuration.

To set up the master inverter:

1. Enter “ParallelSetting” page, choose “Enable” to activate the function for the inverter.



2. Make sure the meter/CT is connected to the master inverter. Enter the “Export Control” page and choose “Meter”/“CT” on the master inverter.

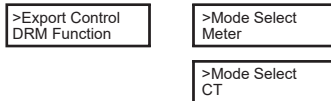

3. Choose “M/S Mode” to select the Master inverter. Only one inverter can be set as “Master”.



4. Set the value for “System Limit” on the master inverter. This will be the overall power limit for parallel system. The output power of slaves will then be distributed respectively according to their nominal output power. The value can be set within the range of 0 kW to 30 kW and the default value is 0 W.

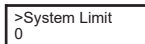

Following to set the slave inverters:

1. Enter “Export Control” page, and the mode status is “Disable” by default (users cannot set by themselves).

>Export Control
DRM Function

>Mode Select
Disable

2. Choose “ParallelSetting” and then set the status of “Pallel Switch” as “Enable”.

>ParallelSetting
MpptScanMode

>Parallel Switch
Enable

3. Enter “M/S Mode” and chose “Slave” to set the Slave inverters.

>M/S Mode
Slave



PLEASE NOTE

The power limit value set in “System Limit” is the limit for the multiple inverters in the parallel system, while the “UserValue” set in “Export Control” is the power limit for a single inverter which will be nullified when the parallel function is enabled.

5.1. Parallel System with Datahub

In this parallel system, at most 60 inverters can be connected. The Datahub will be the master of the system, and all the inverters are the slaves. The Datahub can communicate with all the slave inverters.



PLEASE NOTE

Before attaching the Datahub to the parallel system, ensure the following settings on the inverters are correct: The "ParallelSetting" must be set to "Disable." Each inverter should have a unique address. If not, update the RS485 communication addresses to avoid duplication. The communication address for the meter and each inverter must be distinct to prevent any potential conflicts. The inverter connected with the Datahub should not enable the “ParallelSetting”. There is no need to set the “ParallelSetting” on the inverters, the parallel system with Datahub will start automatically.

Wiring operation:

- a) Connect one terminal of an RS485 communication cable with Datahub, and the other end with one of the slave inverters.

- b) Connect all the slave inverters with each other via RS485 cables.
 - c) Connect the meter with the Datahub and the mains.
- *For more detail please refer to Datahub user manual

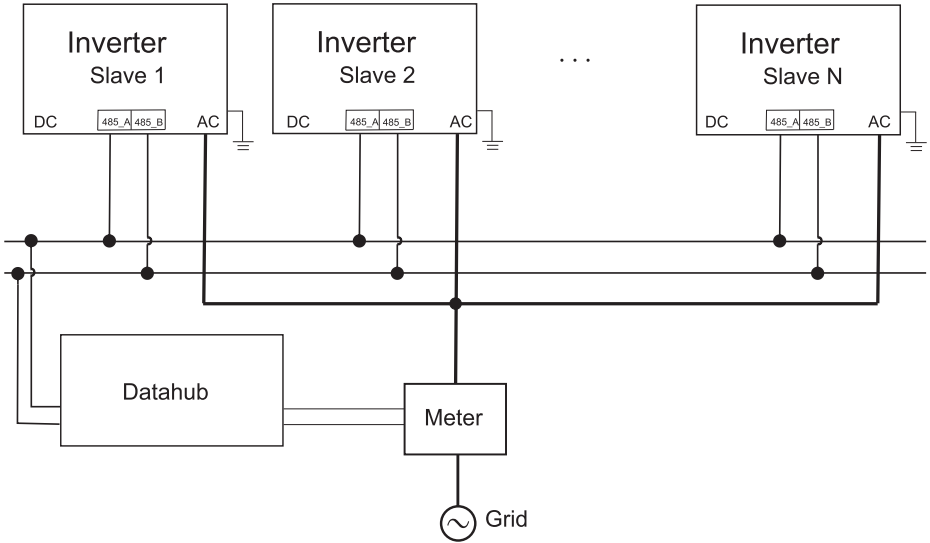

PLEASE NOTE

The parallel system with Modbus function and the EV-Charger function cannot be used simultaneously at this time. If the EV-Charger is connected while multiple inverters are operating in the parallel system, enabling "ParallelSetting" will interrupt the inverter's communication with the EV-Charger. In this scenario, the EV-Charger should have its own CT/Meter installed to function correctly with the parallel inverters. When "ParallelSetting" is disabled, the EV-Charger function is activated, allowing the EV-Charger to operate normally with the connected inverter. However, other inverters will not be able to perform the export control function.

6. Operation

This section outlines basic operation steps for the inverter system.

6.1. Control Panel

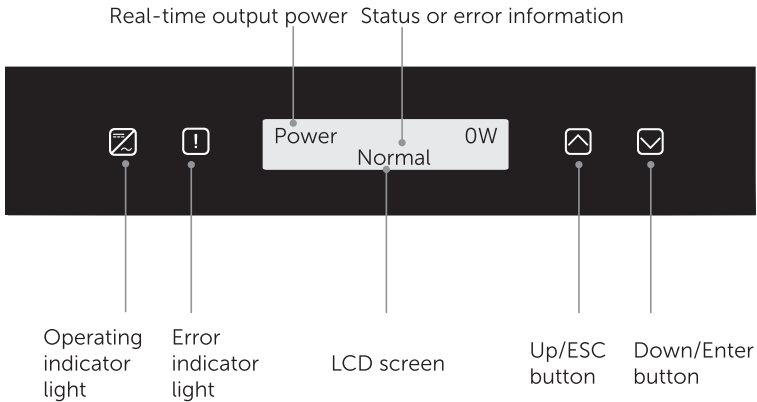

ITEM	DESCRIPTION
LCD Screen	Display the information of the inverter
Operating indicator light	Light in blue: The inverter is in normal status Flash in blue: The inverter is in waiting status
Error indicator	Light in red: The inverter is in fault status
UP/ESC button	UP/ESC button: Short press to move cursor up or increase value. Long press to return from the current interface function.
Down/Enter button	Down/Enter button: Short press to move cursor down or decrease value. Long press to confirm and change parameters.

When the inverter is in “Waiting” and “Checking” status, the blue light “B” is flashing; when in “Normal” status, the blue light “B” is always on.

6.2. LCD Structure

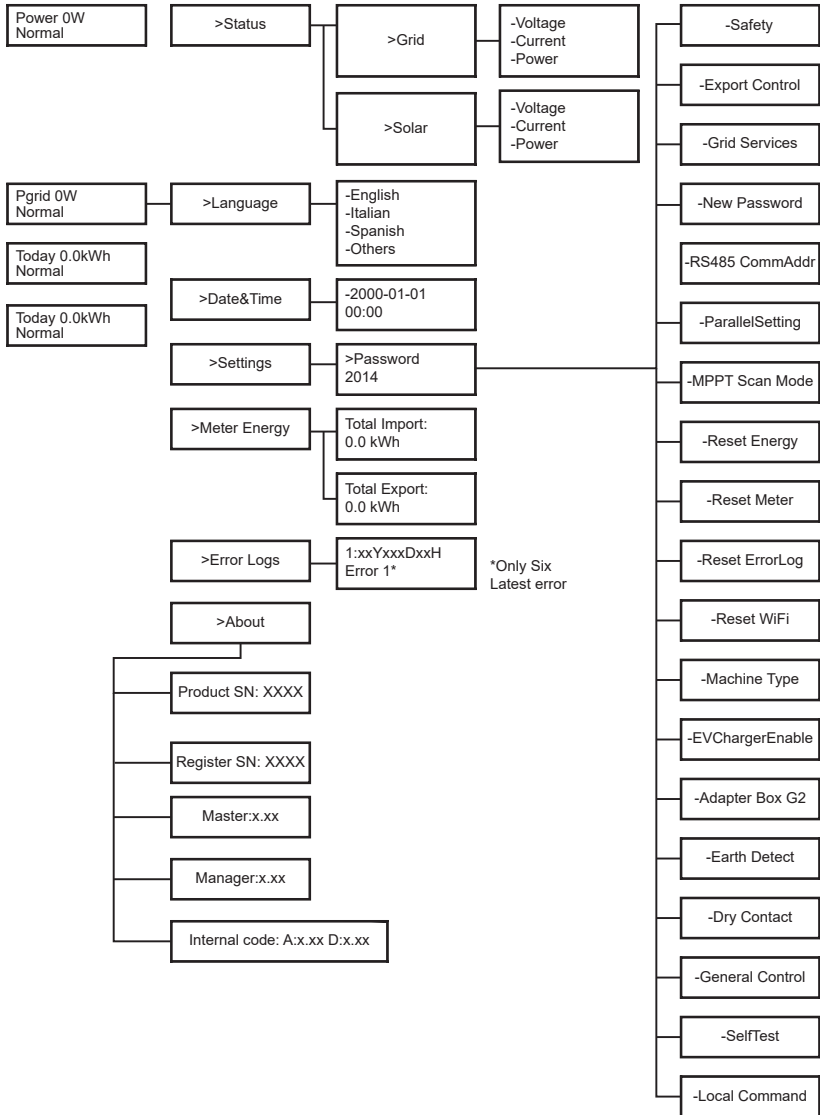

- Level 1:
The first line displays the parameters(Power, Pgrid, Today and Total) an the values.

Parameter	DESCRIPTION
Power	The output power of the inverter
Pgrid	The power export to or import from the grid; (Positive value means the energy feeds into grid, negative value menas the energy used from the grid
Today	The power generated within the day
Total	The power generated in total

- Level 2:
Long press the “Enter” button to access the second-level interface. Users can view parameters such as Status, Language, Date & Time, Settings (password required), Meter Energy (including Total Import and Total Export), Error Logs (for the inverter), and About (which includes details like product serial number, machine type, register SN, master, slave, manager, and internal code).
- A. Status: The status function contains two aspects: the grid and the solar. Press “Up” and “Down” to select and long press “down” to confirm the selection, long press “Up” to return to Menu.

Status	
>Grid	
Solar	

Grid: This status displays the current condition of the inverter's AC output port, including voltage, current, output power, and grid power. It includes 5 parameters: U, I, F, Pout, and Pgrid. Press “Up” and “Down” to navigate, then long press “Down” to confirm the selection. To return, long press “Up”.

Grid	
>U	0.0 V
I	0.0 A

Solar: This status shows the real-time PV condition of the system, including input voltage, current, and power for each PV input. It includes 6 parameters: U1, I1, and P1. Press “Up” and “Down” to navigate, then long press “Down” to confirm the selection. To return, long press “Up”.

Solar	
>U1	0.0 V
I1	0.0 A

- B. **Language:** Users can select a language from English, German, Polish, French, Portuguese, Chinese, Spanish, Italian and Dutch by this option.

Language
>English
German

- C. **Date Time:** This interface allows the user to set the system date and time. Press “Up” or “Down” to increase or decrease the values. Long press “Down” to confirm each selection and move to the next parameter. Once all values are set, long press “Down” to save the date and time.

Date&Time
>2000-01-01
00:00

- D. **Settings:** This option allows the user to sett the inverter with different functions. The default password to access is “2014”, this interface allows the installer to review and adjust necessary settings in compliance with local rules and regulations. For advanced settings, please contact the distributor or us for assistance. To modify values, press the “Up” or “Down” button to increase or decrease. Long press “Down” to confirm each selection and move to the next number. You can find the more information about the function in the next chapter “6.4 Inverter Functions”.
- E. **Meter Energy:** This function allows the user to check the import and export energy. There are four parameters: “Total Import” and “Total Export”. Press “Up” and “Down” to browse the values.

Meter Energy
Total Import
0.0kWh

- G. **About:** This interface shows information of the inverter, including “Product SN”, “Register SN”, “Master”, “Manager” and “Internal Code”.

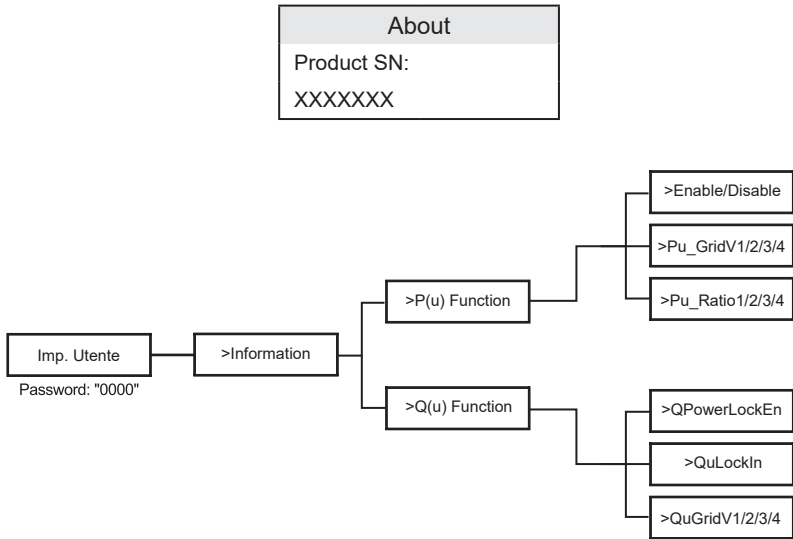

- Level 3:

Long press the “Enter” button to access the third-level interface.

- a Status: View the U/I/P parameters of both the grid and the PV, such as Ugrid, Igrid, P, and F for the grid, and Usolar, Isolar, and Psolar for the PV.
- b Language: The inverter offers multiple language options for the user to choose from.
- c Settings: Enter the installer password to access the LCD interface information displayed on the previous page.
 1. Safety: Set the appropriate safety standard here.
 2. Grid: Typically, end users do not need to adjust the grid parameters. If adjustments are necessary, ensure all changes comply with local grid requirements.

Parameter	Description
O/VStage1	Slow overvoltage point
U/VStage 1	Slow undervoltage point
O/VStage 2	Rapid overvoltage point

UVStage 2	Rapid undervoltage point
O/VStage 3	Stage-3 rapid overvoltage point
UVStage 3	Stage-3 rapid undervoltage point
O/V 10min En	10 min average overvoltage enabled
O/V 10min Set	10min average overvoltage setting value
O/FStage 1	Slow overfrequency point
U/FStage1	Slow underfrequency point
O/FStage 2	Rapid overfrequency point
U/F Stage 1	Raoud underfrequency point
FreqROCOF	Rate frequency change
T_Start	Self-test time
H/LVRTFunction	High/low voltage ride enabled
Frt_EnterVoltDn	Entry value fo low voltage ride through
Qu_3Tau	Reactive step response time constant
Pu_3Tau	Active step response time constant
VacOVP1stTime	Stage-1 overvoltage protection time
VacOVP2ndTime	Stage-2 overvoltage protection time
VacOVP3rdTime	Stage-3 overvoltage protection time
VacUVP1stTime	Stage-1 undervoltage protection time
VacUVP2ndTime	Stage-2 undervoltage protection time
VacUVP3rdTime	Stage-3 undervoltage protection time
FacOFP1stTime	Stage-1 overfrequency protection time
FacOFP2ndTime	Stage-2 overfrequency protection time
FacUFP1stTime	Stage-1 underfrequency protection time
FacUFP2ndTime	Stage-2 underfrequency protection time
ReConnectTime	Reconnect time
Cos_P_Tau3	Power factor step response time constant
Frt_EnterVoltUp	Entry value of high voltage ride through

3. Power Factor: (For specific country if required by the local grid.) There are 6 modes for selecting: Off, Under-Excited, Over-Excited, PF (p), Q (u).

All parameters are shown below.

Parameter	Comment
Off	
Under excited	PFValue
Over excited	PFValue
PF(p)	Entry value of low voltage ride through
	PowerFactor1
	PowerFactor2
	PowerFactor3
	PowerFactor4
	PowerRatio1
	PowerRatio2
	PowerRatio3
	PowerRatio4
	EntryVolt
ExitVolt	
Q(u)	QPowerLockEn
	QuLockIn
	QuLockOut
	QuGridV1/2/3/4
	QuRatioV1/2/3/4
Fixed Q Power	Q Power

6.3. LCD Internal Menus

Here are the different menu levels you can find in the inverter:

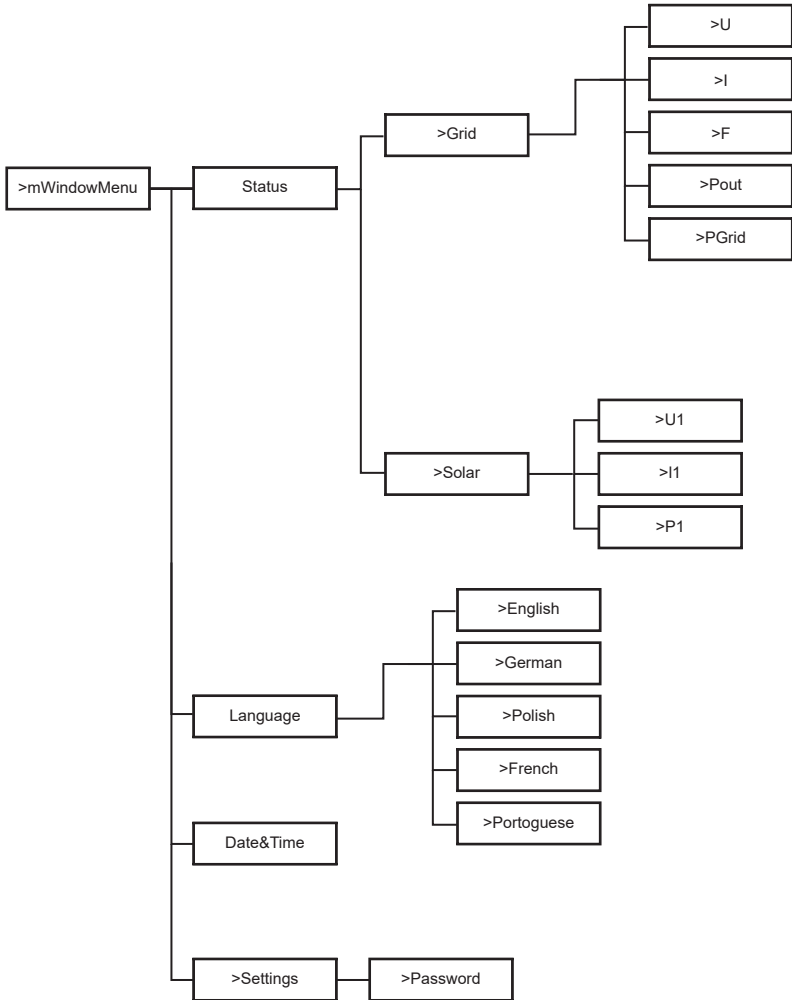

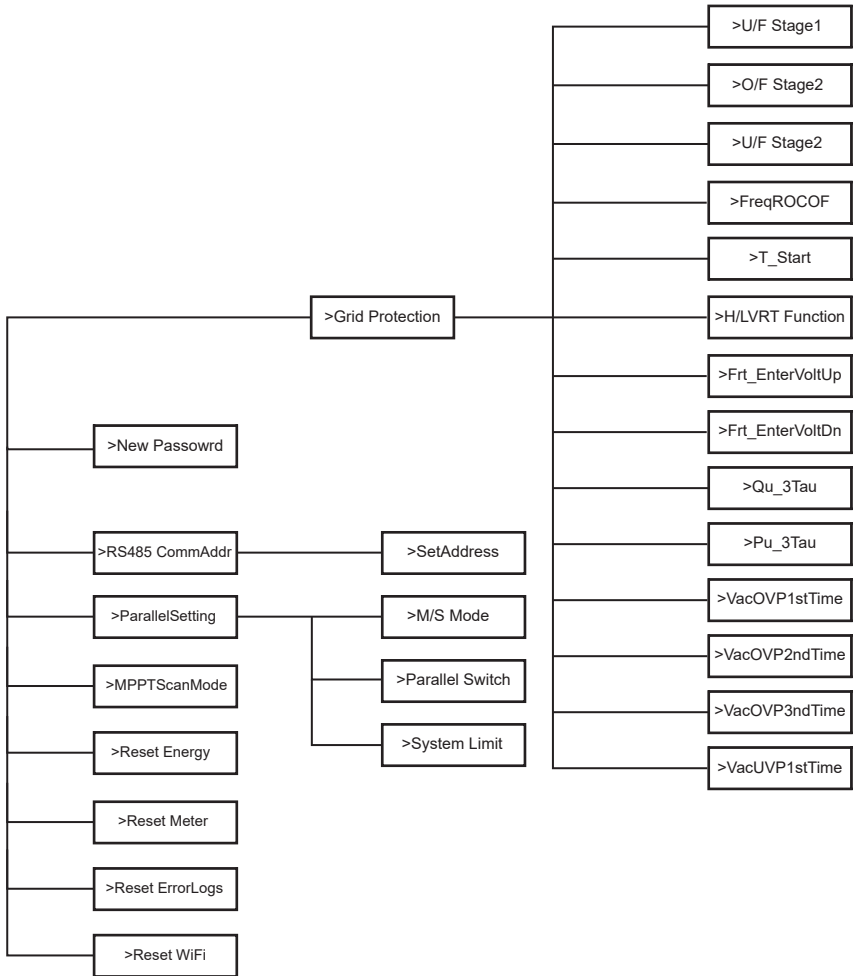

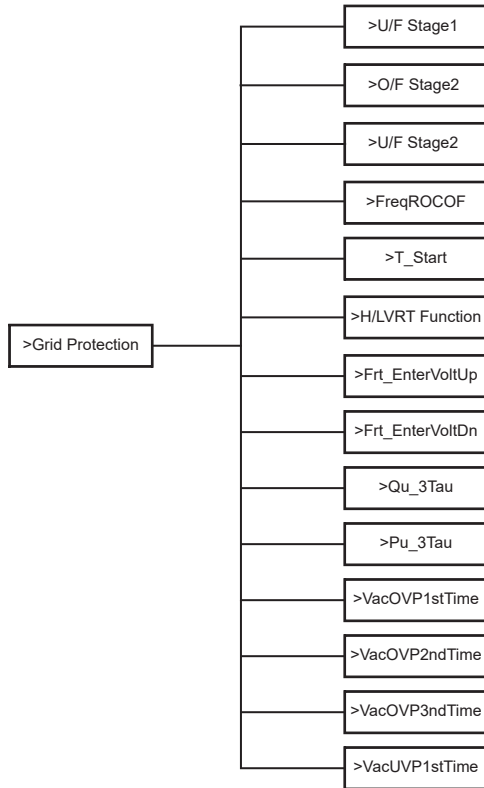

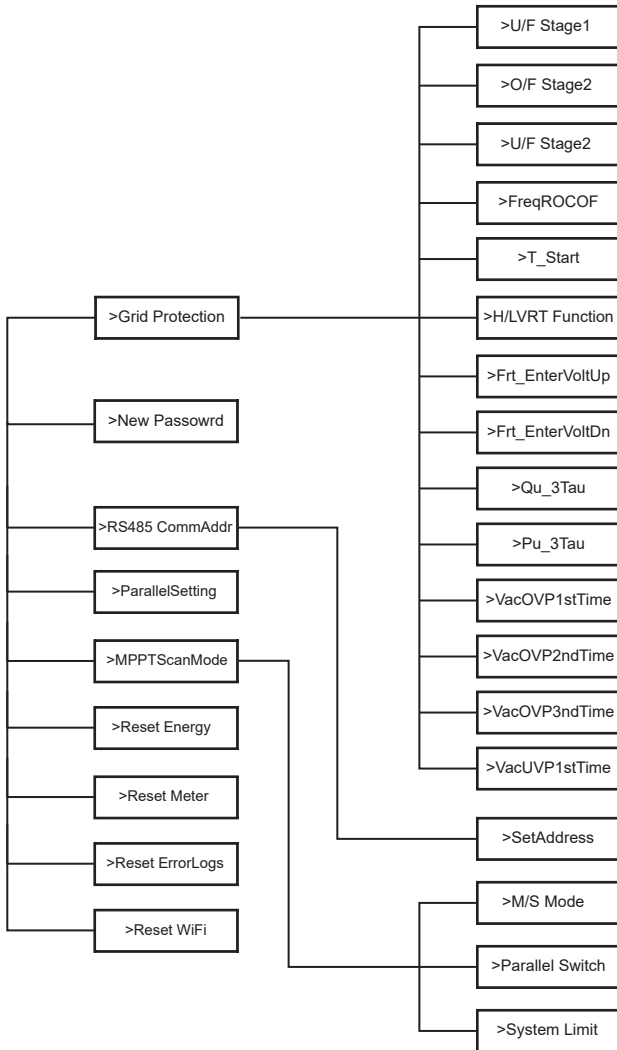

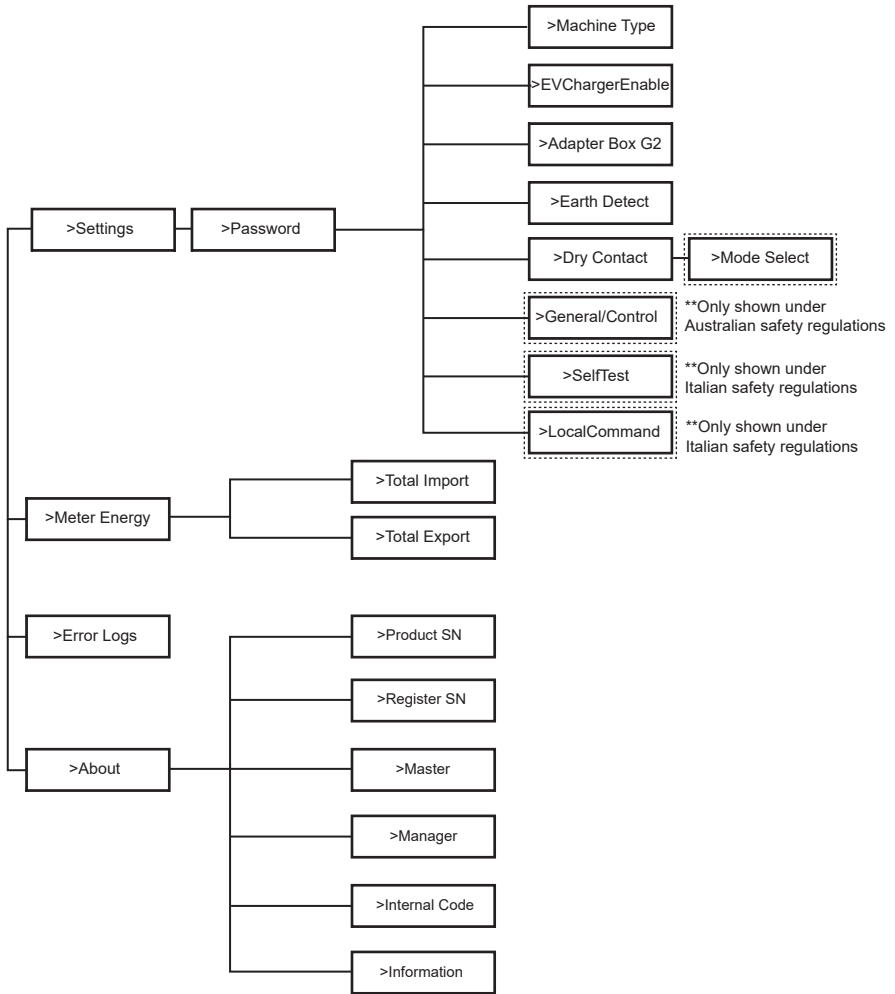

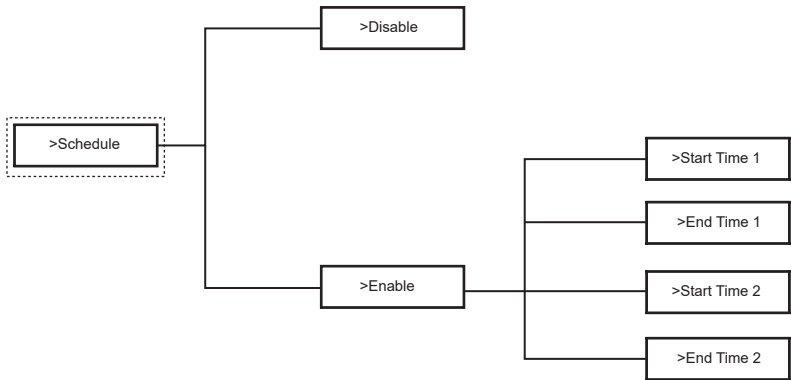
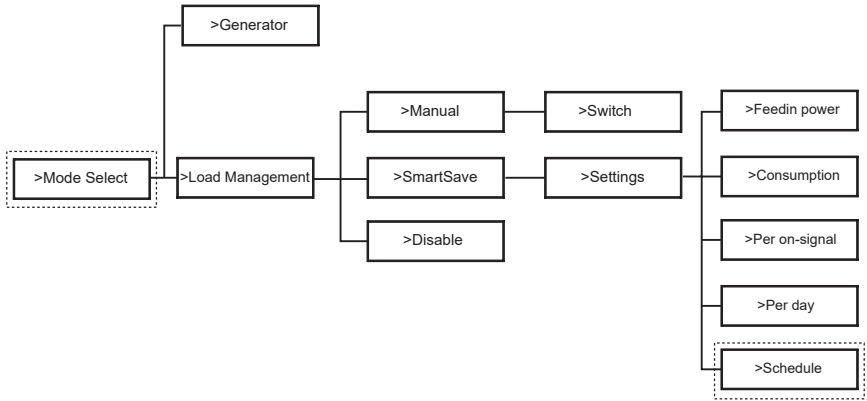

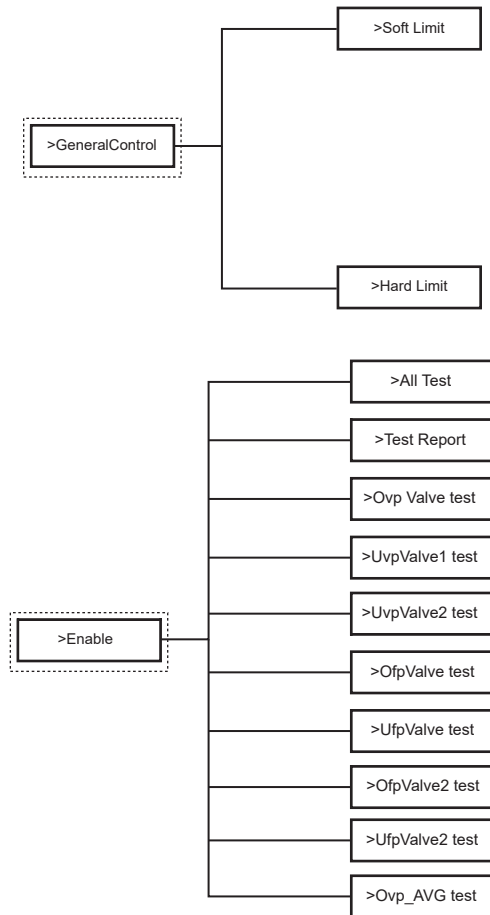

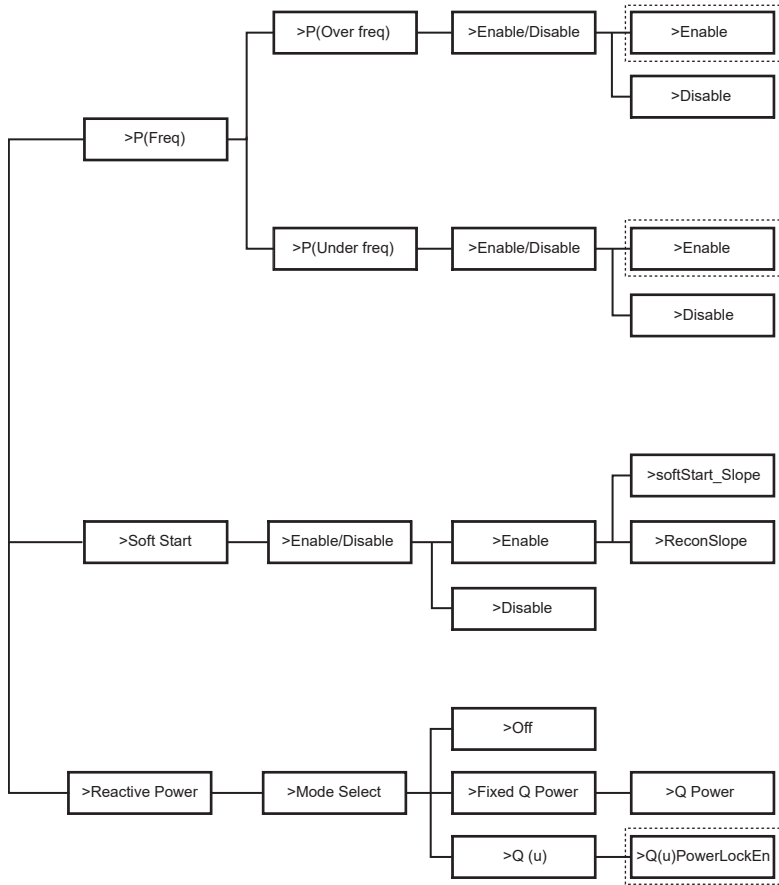

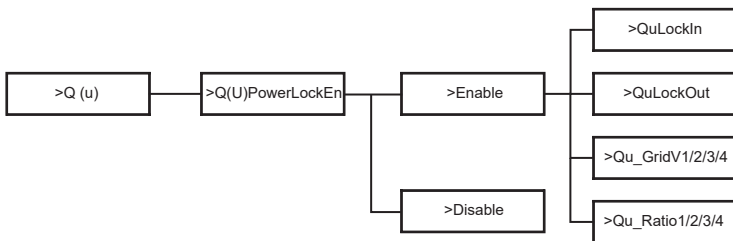
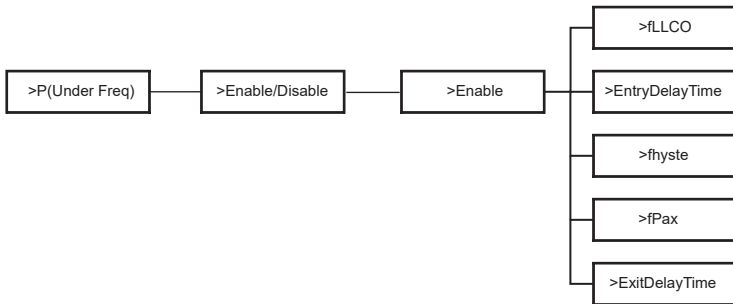
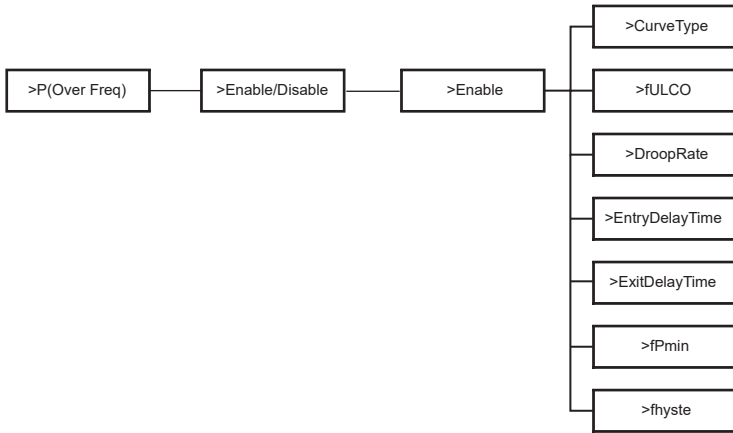

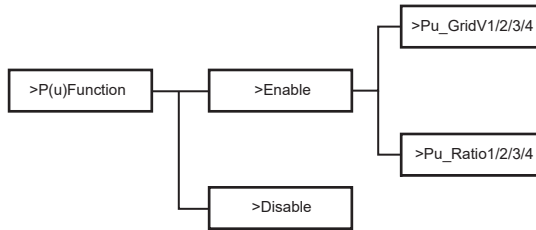

6.4. Inverter Functions

In the option Settings after ingress the default password “2014” , the installer can access different functions that will allow them to manage the device , for example:

- A. **Safety:** The user can configure the safety standard according to the requirements of different countries and grid-tied standards. There are multiple preset standards available, which may change without notice. Additionally, there is a "UserDefined" option that allows users to customize relevant parameters within a broader range.



PLEASE NOTE

The grid standard must be configured according to the requirements of different regions. If there are any doubts, please consult our service technicians for further details.

- B. **Export Control:** This function allows the inverter to control the energy exported to the grid. Activating this function is based on the user's preference. Choosing "Disable" will turn off the function. The user value set by the installer must be within the range of 0 kW to 60 kW. Press the "Up" and "Down" buttons to select and long press "Down" to confirm.
- C. **Grid Services:** Usually, end users do not need to set the grid parameters. All default values have been configured according to safety rules before leaving the factory. If a reset is necessary, any changes should be made in accordance with the requirements of the local grid.
- D. **New password:** The user can set a new password here. To change each character, press the "Up" or "Down" button. Long press "Down" to confirm each character and move to the next one. Once the entire password is entered, long press "Down" to reset the password.
- E. **RS485 CommAddr:** If "Enable" is selected, the inverter will communicate with the computer, allowing the operating status of the inverter to be monitored. When

multiple inverters are monitored by one computer, the RS485 communication addresses of the different inverters need to be set. The RS485 function will only be effective when the addresses are identical. The default address is "1".

- F. ParallelSetting: To use the parallel system with the Modbus Function, enable this function and complete the settings by following the instructions in the "Parallel Connection" section. If the parallel system is not needed, disable this function. Check more info in chapter "3. Installation instructions"
- G. MPPT Scan Mode: There are 4 modes for selection: "Off", "LowFreqScan", "MidFreqScan", and "HighFreqScan". These modes indicate the frequency of PV panel scanning. If "LowFreqScan" is selected, the inverter will scan the PV panel at a low frequency. The scan durations are as follows: LowFreqScan: 4 hours, MidFreqScan: 3 hours, and HighFreqScan: 1 hour.
- H. Reset Energy: The user can clear the power energy of CT and meter by this function (if the user uses meters).
- I. Reset Meter: The user can clear the meter and CT energy by this function. Press "Up" or "Down" button to select and long press "Down" to confirm. (The user can select "Yes" to reset meter if the user uses meters).
- J. Reset Errorlog: The user can clear the error-logs by this function, Press "Up" or "Down" button to select and long press "Down" to confirm.
- K. Reset WiFi: The user can restart the WiFi by this function.
- L. Machine Type: The user can check the Machine Type by this function.
- M. EvChargerEnable: The user can turn on EvCharger function by select "Enable". Check more info in chapter "3. Installation instructions"
- N. Adapter Box G2: The user can connect the adapter box by this function. Check more info in chapter "3. Installation instructions"
- O. Earth Detect: The user can enable or disable the Earth Detec by this function.
- P. Dry Contact: The user can use the Dry Contact to connect heat pump by this function (Require SG Ready).

There are three functions (Disable/Manual/Smart Save) that can be selected for Load Management. "Disable" means the heat pump is off. When "Manual" is selected, the user can manually control the external relay to remain closed or open. In "Smart Save" mode, the user can set the values for the heat pump's on/off time, conditions, and operating modes.

If the user uses the inverter dry contacts to control the heat pump through an Adapter Box, please refer to the Adapter Box Quick Installation Guide to set the parameters here.

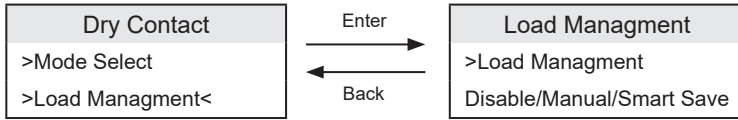

Q. **SelfTest:** The user can test the safety regulations using this function.

7. Monitoring System Configuration



PLEASE NOTE

For each installation, the end user account (installation owner) must always be created and then, if desired, the created installation can be added to the installer's account. Not the other way around.

To obtain an installer account, please email support@peimar.com with the following details:

- Company name
- Reference email address
- Username (characters other than letters, numbers, "@", "_", ".", and spaces are not allowed)
- Inverter SN
- Monitoring SN printed on the Wi-Fi module
- Password

Once you receive the Peimar technical support credentials, you can log in from the link <https://www.peimar-psix-portal.com/#/login> and change the password if necessary.

To monitor the customer's installation, go to:

Device Management > New Devices > + Add and enter the monitoring SN for the Wi-Fi module, then click "OK". If the entire procedure has been followed correctly, after a few minutes it will be possible to observe the production data of the customer's photovoltaic installation.

7.1. Configuration via Wi-Fi module

A Wi-Fi module (PSI-X-H-WIFI or PSI-X-H-WIFI-3.0) is included on many models in the PSI-X1S-XXXX-TL series, which allows remote monitoring of operating status and production data when configured correctly.

- If the module SN starts with SWxxxxxx, the procedure can only be carried out through the browser.
- If the module SN starts with SXxxxxxxxx or SVxxxxxxxx, the connection procedure can be carried out both through the browser and through the App.
- It is recommended to connect to the main Wi-Fi line, since connecting to repeaters/Wi-Fi does not guarantee data will be sent to the server.

7.1.1. Configuration using the Wi-Fi module from the browser

Connect the Wi-Fi module to the appropriate USB port on the bottom of the inverter (WIFI for PSI-X3P-HY series inverters, Upgrade/Dongle for PSI-X1P-HY and PSI-X3S-HY series inverters, DONGLE for PSI-X1S-TL/TLM and PSI-X3P-TP/TPM series inverters). The LED on the back will start flashing (LED not present on the PSI-X-H-WIFI-3.0 model).

Use a laptop or smartphone and search for the Wi-Fi access point on the device, usually named Wifi_Sxxxxx (Sxxxxxxx=code printed on the Wi-Fi module itself).

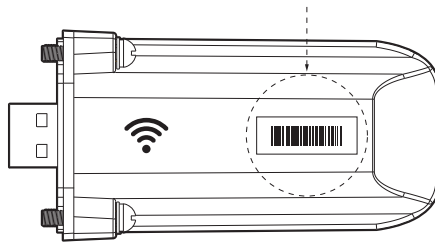

Connect to the hotspot permanently, click “connect” and wait for confirmation (it is normal to see a message that there is no internet connection).

Open your browser and type <http://192.168.10.10/> in the address bar.



PLEASE NOTE

For older inverter models, which have a PSI-X-H-WIFI USB stick (or for PSI-X-H-WIFI-3.0 USB sticks with SN starting with SX) use the address <http://5.8.8.8/> (Usually typing 5.8.8 in the address bar is sufficient) Be careful not to connect to the address <https://5.8.8.8/>.

- Enter “admin” as the username.
- Enter the following as the password:
 - “admin” if the module SN starts with SWxxxxxxxx

- Code printed on the module itself if the module SN starts with SXxxxxxx or SVxxxxxx.
- Go to the “Setting Page” and click the “Find AP” button to search for available Wi-Fi networks.



PLEASE NOTE

The network name and password must contain only numbers or letters, special characters are not accepted.

- The LED on the module, if present, will start flashing rapidly. When it remains lit with a fixed light, after approximately 20 seconds, it means that the Wi-Fi module has connected to the router.
- Connect to the USB flash drive again.
- Connect again to the http address indicated above to check that the data entered has been stored correctly and that the IP address is present to ensure that the connection has been made correctly.

Create an end user account

Once the monitoring system has been correctly configured, to view the production data on the portal, go to <https://peimar-psix-portal.com/#/login> and create a new end-user account by clicking the “Register” button.

Create new user

* SN for tracking

* Username

* Password for accessing

* Confirm the password

* Status

* Time zone

* Plant power (kW)

* Email

Username

Telephone

* Position

In the “Monitoring SN” field, enter the code printed on the module itself and on the label attached to the box. Once all the mandatory fields have been filled in (Italy time zone UTC +01:00), press the “Register” button to complete the registration.

Press the “Back” button and identify yourself with the credentials you have just created.

If the entire procedure has been followed correctly, after a few minutes it will be possible to observe the production data of the photovoltaic installation.

7.1.2. Configuration via Wi-Fi module from the app

- Download the Peimar X Portal app from the store



App Store



Google Play Store

- Choose the language by pressing the 3 dots in the upper left corner.
- Press the “Create new account” button, type or scan the monitoring SN printed on the Wi-Fi module itself and press the “Next” button.

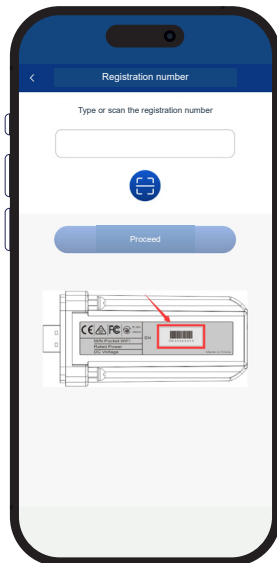

- To create a new account, enter the required data (Italy time zone UTC +01:00) and press “OK”.

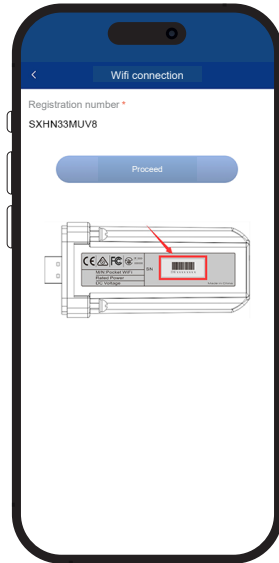

- When the message “Peimar X portal wants to access the Wi-Fi network” appears, press the “Access” option.
- Enter the name of your home Wi-Fi network (SSID) and its password



PLEASE NOTE

The network name and password must contain only numbers or letters, special characters are not accepted.

If the entire procedure has been followed correctly, the LED on the module, if present, will light up with a steady light and after a few minutes the app will start receiving production data from the inverter and can be viewed remotely.

7.2. Configuration via Ethernet cable (LAN) with PSI-X-H-ETH-3.0

If the Wi-Fi signal is too weak, it is also possible to connect to the server via an Ethernet cable. To do this, you need to purchase the PSI-X-H-ETH-3.0 module with an Ethernet port, which allows you to connect the inverter to your home router via a data cable (the Ethernet module is already included in the PSI-X3P-TPM three-phase grid inverters).

Connect the Ethernet module to the corresponding USB port on the bottom of the inverter (WIFI for PSI-X3P-HY series inverters, Upgrade/Dongle for PSI-X1P-HY and PSI-X3S-HY series inverters, DONGLE for PSI-X1P-TL/TLM and PSI-X3P-TP/TPM series inverters).

The installer must provide a Category 5e or higher data cable.

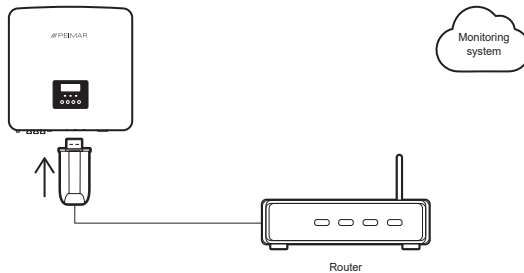

PLEASE NOTE

To complete the configuration of the monitoring system, the same procedure described in the “Creating an end-user account” sections must be followed for configuration via the Wi-Fi module from the browser or App.

The procedure described in the “Connection procedure” section is not necessary since the connection is made directly by cable.

When asked to enter the “Monitoring SN” enter the code on the Ethernet module label instead of the code on the Wi-Fi module label.

8. Troubleshooting

This section contains information and procedures for solving potential problems with the inverters and provides troubleshooting tips to identify and resolve most issues that could occur. It will help you narrow down the source of any problems you may encounter. Please follow these troubleshooting steps:

1. Check warnings or fault messages on the System Control Panel or fault codes on the inverter information panel. If a message is displayed, record it before proceeding.
2. Attempt the solution indicated in the troubleshooting lists.
3. If the inverter's information panel is not displaying a fault light, check the following to ensure the installation allows proper operation:
 - Is the inverter located in a clean, dry, and adequately ventilated place?
 - Have the DC input breakers been opened?
 - Are the cables adequately sized and short enough?
 - Are the input and output connections and wiring in good condition?
 - Are the configuration settings correct for your particular installation?
 - Are the display panel and the communications cable properly connected and undamaged?

If the problem persists, contact our Customer Service for further assistance. Please be prepared to describe details of your system installation and provide the model and serial number of the unit.

CODE	FAULTS	DIAGNOSIS AND SOLUTIONS
IE: 0101	Over Current Fault	<ul style="list-style-type: none"> - Wait for about 10 seconds to check if the inverter is back to normal. - Disconnect the DC switch and restart the inverter. - Contact Peimar for help.
IE: 0102	TzFault	<ul style="list-style-type: none"> - Wait for about 10 seconds to check if the inverter is back to normal. - Disconnect the DC switch and restart the inverter. - Contact Peimar for help.
IE: 0103	Over Current Fault	<ul style="list-style-type: none"> - Wait for about 10 seconds to check if the inverter is back to normal. - Disconnect the DC switch and restart the inverter. - Contact Peimar for help.
IE: 0201	GridLostFault	<ul style="list-style-type: none"> - Check if the mains cable is loose. - Wait for a while and the system will reconnect when the utility is back to normal. - Contact Peimar for help.

IE: 0301	GridVoltFault	<ul style="list-style-type: none"> - Check if the voltage is within the operating range (Settings > Status > Grid > U). - Wait for a while and the system will reconnect when the utility is back to normal. - Contact Peimar for help.
IE: 0304	GridVoltFault	<ul style="list-style-type: none"> - Check if the voltage is within the operating range (Settings > Status > Grid > U). - Wait for a while and the system will reconnect when the utility is back to normal. - Contact Peimar for help.
IE: 0307	GridVoltFault	<ul style="list-style-type: none"> - Check if the voltage is within the operating range (Settings > Status > Grid > U). - Wait for a while and the system will reconnect when the utility is back to normal. - Contact Peimar for help.
IE: 0310	GridVoltFault	<ul style="list-style-type: none"> - Check if the voltage is within the operating range (Settings > Status > Grid > U). - Wait for a while and the system will reconnect when the utility is back to normal. - Contact Peimar for help. - Check if the voltage is within the operating range (Settings > Status > Grid > U).
IE: 0312	GridVoltFault	<ul style="list-style-type: none"> - Check if the voltage is within the operating range (Settings > Status > Grid > U). - Wait for a while and the system will reconnect when the utility is back to normal. - Contact Peimar for help.
IE: 0401	GridFreqFault	<ul style="list-style-type: none"> - Check if the frequency is within the operating range (Settings > Status > Grid > F). - Wait for a while and the system will reconnect when the utility is back to normal. - Contact Peimar for help.
IE: 0404	GridFreqFault	<ul style="list-style-type: none"> - Check if the frequency is within the operating range (Settings > Status > Grid > F). - Wait for a while and the system will reconnect when the utility is back to normal. - Contact Peimar for help.
IE: 0407	GridFreqFault	<ul style="list-style-type: none"> - Check if the frequency is within the operating range (Settings > Status > Grid > F). - Wait for a while and the system will reconnect when the utility is back to normal. - Contact Peimar for help.
IE: 0501	PVVoltFault	<ul style="list-style-type: none"> - Check whether the PV is overvoltage (Settings > Status > Solar > U1 / U2 / U3). - Contact Peimar for help.
IE: 0502	PVVoltFault	<ul style="list-style-type: none"> - Check whether the PV is overvoltage (Settings > Status > Solar > U1 / U2 / U3). - Contact Peimar for help.

IE: 0503	PVVoltFault	<ul style="list-style-type: none"> - Check whether the PV is overvoltage (Settings > Status > Solar > U1 / U2 / U3). - Contact Peimar for help.
IE: 0601	BusVoltFault	<ul style="list-style-type: none"> - Check if the PV input voltage is within the operating range of the inverter (Settings > Status > Solar > U1 / U2 / U3). - Disconnect PV wiring and reconnect. - Contact Peimar for help.
IE: 0604	BusVoltFault	<ul style="list-style-type: none"> - Check if the PV input voltage is within the operating range of the inverter (Settings > Status > Solar > U1 / U2 / U3). - Disconnect PV wiring and reconnect. - Contact Peimar for help.
IE: 0607	BusVoltFault	<ul style="list-style-type: none"> - Check if the PV input voltage is within the operating range of the inverter (Settings > Status > Solar > U1 / U2 / U3). - Disconnect PV wiring and reconnect. - Contact Peimar for help.
IE: 0801	GridVolt10MFault	<ul style="list-style-type: none"> - Check if the voltage is within the operating range (Settings > Status > Grid > U). - The system will reconnect when the utility is back to normal. - Contact Peimar for help.
IE: 0901	DclnjOCP	<ul style="list-style-type: none"> - Wait for a while to check if the inverter is back to normal. - Contact Peimar for help.
IE: 0904	DclnjOCP	<ul style="list-style-type: none"> - Wait for a while to check if the inverter is back to normal. - Contact Peimar for help.
IE: 1001	HardLimitFault	<ul style="list-style-type: none"> - Check if the actual output voltage exceeds the set user value for Hard Limit. - Wait for a while to check if the inverter is back to normal. - Contact Peimar for help.
IE: 1101	SW OCP Fault	<ul style="list-style-type: none"> - Wait for a while to check if the inverter is back to normal. - Disconnect PV and grid, then reconnect. - Contact Peimar for help.
IE: 1104	SW OCP Fault	<ul style="list-style-type: none"> - Wait for a while to check if the inverter is back to normal. - Disconnect PV and grid, then reconnect. - Contact Peimar for help.
IE: 1201	ResidualOCP	<ul style="list-style-type: none"> - Wait for a while to check if the inverter is back to normal. - Contact Peimar for help.

IE: 1202	ResidualOCP	<ul style="list-style-type: none"> - Wait for a while to check if the inverter is back to normal. - Contact Peimar for help.
IE: 1203	ResidualOCP	<ul style="list-style-type: none"> - Wait for a while to check if the inverter is back to normal. - Contact Peimar for help.
IE: 1204	ResidualOCP	<ul style="list-style-type: none"> - Wait for a while to check if the inverter is back to normal. - Contact Peimar for help.
IE: 1301	IsoFault	<ul style="list-style-type: none"> - Check the connections of the inverter. - Contact Peimar for help.
IE: 1401	OverTempFault	<ul style="list-style-type: none"> - Check if the inverter and the ambient temperature exceed the operating range. - Contact Peimar for help.
IE: 1402	OverTempFault	<ul style="list-style-type: none"> - Check if the inverter and the ambient temperature exceed the operating range. - Contact Peimar for help.
IE: 1403	OverTempFault	<ul style="list-style-type: none"> - Check if the inverter and the ambient temperature exceed the operating range. - Contact Peimar for help.
IE: 1601	EarthFault	<ul style="list-style-type: none"> - Check if the inverter is properly grounded. - Contact Peimar for help.
IE: 2201	Arc Fault	<ul style="list-style-type: none"> - Wait for 5 minutes. - Contact Peimar for help if it cannot return to normal.
IE: 2401	Fan Fault	<ul style="list-style-type: none"> - Check if the fan is working. - Contact Peimar for help.
IE: 2501	InternalComFault	<ul style="list-style-type: none"> - Restart the inverter to check if it is back to normal. - Update the ARM software or reboot the program. - Contact Peimar for help.
IE: 2801	EEPROMFault	<ul style="list-style-type: none"> - Disconnect PV wiring and reconnect. - Contact Peimar for help.
IE: 2802	EEPROMFault	<ul style="list-style-type: none"> - Disconnect PV wiring and reconnect. - Contact Peimar for help.
IE: 2901	RcDeviceFault	<ul style="list-style-type: none"> - Restart the inverter. - Update the ARM software or reboot the program. - Contact Peimar for help.
IE: 3001	PvConnDirFault	<ul style="list-style-type: none"> - Check if the PV+/- sides are connected correctly. - Contact Peimar for help.

IE: 3002	PvConnDirFault	<ul style="list-style-type: none"> - Check if the PV+/- sides are connected correctly. - Contact Peimar for help.
IE: 3101	GridRelayFault	<ul style="list-style-type: none"> - Check the grid connection. - Restart the inverter. - Contact Peimar for help.
IE: 3102	GridRelayFault	<ul style="list-style-type: none"> - Check the grid connection. - Restart the inverter. - Contact Peimar for help.
ME: 0901	Mgr EEPROM Fault	<ul style="list-style-type: none"> - Disconnect PV and grid, then reconnect. - Contact Peimar for help.
ME: 0092	Meter Fault	<ul style="list-style-type: none"> - Check the connection of the meter. - Check if the meter is in working order. - Contact Peimar for help.
ME: 0093	PowerTypeFault	<ul style="list-style-type: none"> - Check the version of ARM and DSP. - Check the product SN number. - Contact Peimar for help.
ME: 0094	Mgr Comm Fault	<ul style="list-style-type: none"> - Restart the inverter to check if it is back to normal. - Contact Peimar for help.
ME: 0095	ComTimeOut20305	<ul style="list-style-type: none"> - Check the connection of the WiFi module. - Contact Peimar for help.
/	Screen not on	<ul style="list-style-type: none"> - Check if the inverter correctly and normally connected to PV or grid. - Contact Peimar for help if the inverter is connected correctly.
/	Abnormal sound on fan	<ul style="list-style-type: none"> - Contact Peimar for help.
/	Screen on but no content display	<ul style="list-style-type: none"> - Contact Peimar for help.
/	LCD screen display stuck in Waiting state	<ul style="list-style-type: none"> - Check if the input voltage of PV is greater than 50 V. - If the input voltage of PV is less than 50 V, check the PV connection. - Contact Peimar for help.
/	No readings after CT connection	<ul style="list-style-type: none"> - Check if CT is correctly clipped on the L wire. - Check if the arrow on the CT points at the grid. - Contact Peimar for help if it cannot return to normal.
/	No readings on Load (on App or Web)	<ul style="list-style-type: none"> - Check if the load is connected correctly. - Check if the power of load on the LCD screen displays normally. - Contact Peimar for help if it cannot return to normal.

/	No readings on Grid (on App or Web)	<ul style="list-style-type: none"> - Check if the grid connection is normal. - Check if the grid parameter on the LCD screen displays normally. - Check if the monitoring module works normally. - Contact Peimar for help if it cannot return to normal.
/	No feedin data (on App or Web)	<ul style="list-style-type: none"> - Check if the meter/CT is connected correctly. - Check if the meter/CT parameter on the LCD screen displays normally. - Check if the monitoring module works normally. - Contact Peimar for help if it cannot return to normal.
/	No data on App or Web	<ul style="list-style-type: none"> - Check if the monitoring module works normally. - Contact Peimar for help.

8.1. Maintenance Routine

In most conditions, inverters do not require maintenance or correction. However, if the inverter frequently loses power due to overheating, the following could be the reason:

- The cooling fins on the rear of the unit are covered with dirt. Clean the cooling fins with a soft, dry cloth or brush if necessary.

Only trained and authorized professional personnel who are familiar with safety requirements are allowed to perform servicing and maintenance work.

Safety Checks

Safety checks should be performed at least every 12 months by a qualified person from the manufacturer who has adequate training, knowledge, and practical experience to perform these tests. The data should be recorded in an equipment log. If the device is not functioning properly or fails any test, it must be repaired. For detailed safety check instructions, refer to section 2 of this manual, Safety Instruction and EC Directives.

Periodic Maintenance

Only qualified personnel may perform the following tasks:

1. Inspect the cooling fins on the rear of the unit for dirt. Clean and remove dust if necessary. This inspection should be performed regularly.
2. Check if the indicators on the inverter are functioning normally, verify that the keys are operational, and ensure the display is working correctly. This check should be performed at least every 6 months.
3. Inspect the input and output wires for damage or aging. This check should be performed at least every 6 months.
4. Clean the inverter panels and check their security at least every 6 months.

9. Disposal



This device MUST NOT be disposed as a municipal waste.

The crossed-out wheeled bin symbol on the appliance's label indicates that the product, at the end of its useful life, must be collected separately from other waste to allow for proper treatment and recycling. Therefore, at the end of its useful life, the user must hand over the appliance free of charge to the appropriate municipal selective collection centres for electrical and electronic waste. Appropriate separate collection for subsequent recycling, treatment and disposal of the appliance in an environmentally compatible manner helps to avoid possible negative effects on the environment and on health and encourages the reuse and/or recycling of the materials that make up the appliance. Illegal disposal of the product by the user will result in the application of the penalties established by law.



WARNING!

Before dispose the inverter, ensure that the DC switch is disconnected, and then unplug the PV and AC cables to avoid an electric shock hazard. Do not touch any internal live parts for at least 10 minutes after disconnecting the inverter from the utility grid and the PV input.

10. Warranty Conditions

To find out the warranty conditions, please refer to the corresponding document that you can download from www.peimar.com.

/// PEIMAR



info@peimar.com | www.peimar.com