

PSI-X3P100000-TPM PSI-X3P125000-TPM

EN

THREE-PHASE ON GRID INVERTER

User Manual



/// PEIMAR

It is specified that the technical data, information and representations reported in this document maintain a purely indicative value. Peimar reserves the right to modify the data, drawings and information contained in this document at any time and without notice.

/// PEIMAR

Introduction8

1. Security measures8

 1.1. Security tips 8

 1.2. Legend of safety symbols8

 1.3. Safety instructions9

 1.4. Key to symbols on the label 12

2. Product information14

 2.1. Field of application 14

 2.2. Product model specifications 14

 2.3. Dimensions of the products 14

 2.4. Packing list 15

3. Installation hypothesis16

 3.1. Packing check 16

 3.2. Place of installation 16

 3.3. Methods of installation and placement 17

 3.4. Assembly procedure 19

4. Installation hypothesis20

5. Electrical connection22

 5.1. Connection inputs for the inverter 22

 5.2. PV connection 22

 5.3. AC Connection 30

 5.4. Meter connection 33

 5.4.1. Meter PSI-X-3PMETER-HY..... 33

 5.4.2. Meter PSI-X-3PMETER-HY-CT 36

6. Earth connection	43
7. Parallel conn. of multiple PSI-X3P-TPM series inverters	44
8. Starting the inverter	45
9. Setting and display interface	46
10. Block diagram of the inverter screens	47
11. Main functions on display	48
12. Firmware version	52
13. Inverter monitoring system configuration	53
13.1. Installer account creation	53
13.2. Configuration via Wi-Fi module	53
13.2.1. Configuration via browser Wi-Fi module	54
13.2.2. Configuration via Wi-Fi module from app	56
13.3. Configuration via Ethernet cable (LAN) with PSI-XH-ETH-3.0	59
14. Error codes and troubleshooting	61
15. Periodic maintenance	65
16. Disposal	65
17. Warranty conditions	65

Introduction

This user manual defines detailed instructions and procedures for the installation, operation, maintenance and troubleshooting of the following three-phase grid connected Peimar inverters:

PSI-X3P100000-TPM	PSI-X3P125000-TPM
--------------------------	--------------------------

Please always keep this manual available in case of need.

1. Security measures

1.1. Security tips

The inverter is a device directly connected to a HIGH VOLTAGE electric generator; The installation, maintenance and repair of the inverter can only be carried out by qualified personnel, who have carefully read and fully understood all the safety regulations contained in this manual.

Keep the user manual properly.

1.2. Legend of safety symbols



DANGER

Indicates a hazardous situation which, if not avoided, will result in death or serious injury.



WARNING

Indicates a hazardous situation which, if not avoided, could result in death, serious injury, or moderate injury.



ATTENTION

Indicates a hazardous condition which, if not avoided, could result in minor or moderate injury.



NOTICE

Indicates a situation that could lead to potential damage if not avoided.

1.3. Safety instructions



DANGER

1. The user must comply with the applicable electrical codes, national and local regulations during the installation, operation and maintenance of the inverter, to avoid incurring personal injury or death, and damage to the inverter.
2. Do not touch any parts of the inverter while it is operating; there is a risk of fatal electric shock due to high voltage.
3. To prevent the risk of an electric shock during installation and maintenance, please make sure that all AC and DC terminals are disconnected from the inverter, and never touch the positive and negative pole of the PV connection device simultaneously.
4. Make sure that the existing wiring is in good condition and that the cables are not undersized. The wiring must be carried out in a way so that the length of the cables is as short as possible.
5. Do not touch the inverter surface while the coating is wet; could cause an electric shock.
6. Do not stay close to the inverter during bad weather conditions including storm, lightning, etc.
7. Before touching the coating, the inverter must be disconnected from the grid and from the photovoltaic generator; it is necessary to wait at least five minutes to allow the energy storage capacitors to fully discharge after being disconnected from the energy source. It is necessary to measure the voltage between the positive and negative poles of the PV connecting device to ensure that the device is discharged before carrying out any work on the inverter.
8. The island effect is a particular phenomenon where the photovoltaic system continues to feed energy into the grid even when there is a grid loss in the electricity system; this is a dangerous phenomenon for maintenance personnel and the public. The inverters of this series are equipped with an integrated protection to avoid the islanding effect.
9. The inverters of this series are equipped with a certified internal residual current device to protect against possible electric shock and fire hazards in the event of a malfunction of the PV array, cables or inverter. If the local regulations require an external differential switch, install a magneto-thermal differential switch

downstream of the AC side output, with a differential of at least type A (a type A or F differential is recommended) and a tripping threshold $I_{dn}=0.3A$ differential switch.



WARNING

- 1 The installation, maintenance, recycling and disposal of the inverters must be carried out only by qualified personnel, in compliance with the national and local laws and regulations in force with the use of suitable equipment. Prevent the inverter from being used by children or unqualified personnel.
- 2 Any unauthorized action, including the modification of any type of product functionality, may result in damage to the components and a lethal danger to the operator, or to third parties. Do not disassemble the inverter parts not mentioned in the installation guide. In an event of improper modifications Peimar is not responsible for any damage and abstains from any liability relating to the guarantee of the aforementioned product.
- 3 The Peimar inverter must only be used in combination with photovoltaic panels only, in compliance with current regulations; do not connect other energy sources to the Peimar inverter.
- 4 Use only the recommended accessories, otherwise there is a risk of fire, electric shock, or injury.
- 5 Make sure that the photovoltaic generator and the inverter are correctly connected to the earth system; Improper grounding can cause personal injury, death, or equipment malfunction and increase electromagnetic emissions. Make sure that the ground conductor is adequately sized as required by the safety standards. Do not connect the earth terminals of the unit in series in case of multiple installation.
- 6 Staying within 20cm of the inverter for a long time may cause harm to health due to radiation.
- 7 Keep away from flammable and explosive materials to avoid fire.

**ATTENTION**

1. The photovoltaic inverter can reach high temperatures during operation. Please do not touch the heat sink or side surface during operation or immediately after power off to avoid the risk of burns.
2. To prevent damage and personal injury, hold the inverter firmly when moving it, as it is a heavy piece of equipment.

**NOTICE**

1. The photovoltaic inverter is designed to feed alternating current energy directly into the public electricity grid; do not connect the AC output of the inverter to any device that is not connected to the electricity grid.
2. There may be damage to the photovoltaic system both due to direct lightning strikes and overvoltages to nearby discharges. Induced surges are the most likely cause of damage especially in rural areas where electricity is usually supplied by long power lines. Induced surges are the most likely cause of damage especially in rural areas where electricity is usually supplied by long power lines. Overvoltage can be induced both on DC cables and on AC cables leading into the building. The project planner, on the basis of the lightning risk and what is required by current legislation, will evaluate the need to install any additional external surge arresters with respect to the type II SPDs already supplied with the inverter, for the protection of the photovoltaic side and AC side.

1.4. Key to symbols on the label



DANGEROUS ELECTRIC VOLTAGE

This device is directly connected to the public electricity grid, therefore any work on the inverter must be carried out by qualified personnel.



DANGER TO LIFE due to high voltage!

There may be residual voltage in the inverter due to the high capacity of the condenser. Wait 5 MINUTES after disconnecting the appliance before touching the coating or carrying out maintenance on the system



WARNING, DANGER!

The appliance is directly connected to electric generators and to the public electricity grid.



DANGER HOT PARTS

The elements inside the inverter reach high temperatures during operation. Do not touch the metal case when the inverter is active (risk of burns).



This device MUST NOT be disposed off as municipal waste.

Please refer to the "Disposal" chapter of this manual for proper management of the disposal of the inverter.

**WITHOUT TRANSFORMER**

This inverter does not have an isolation transformer.

**EARTHING**

This inverter does not have an isolation transformer.

**CE MARK**

Devices with the CE mark comply with the fundamental requirements of the Low Voltage Directive and the Electromagnetic Compatibility Directive.

RoHS RoHS

This device complies with the ROHS (Restriction of Hazardous Substances Directive).

**INSTRUCTIONS**

Refer to the present manual for inverter installation, operation, maintenance, and troubleshooting instructions.

2. Product information

2.1. Field of application

The inverters in this manual are three-phase grid inverters, which receive electricity generated in direct current (DC) by photovoltaic panels and convert it into alternating current (AC), in accordance with the requirements of the public grid.

These inverters support the type of connection: TN-S, TN-C, TN-C-S, TT and IT according to the following diagram.

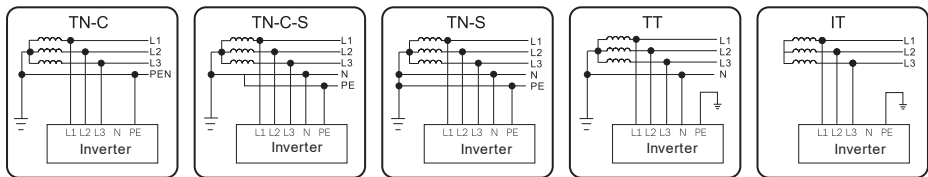

2.2. Product model specifications

PSI-X3PXXXX-TPM

- PSI-X3P indicates the series name of the inverter.
- XXXX indicates the nominal power in W of the inverter.
- TPM indicates that it is a three-phase inverter with multiple MPPT without a transformer.

2.3. Dimensions of the products

All inverters of the PSI-X3P-TPM series in this manual have the same dimensions, indicated in the following figure:

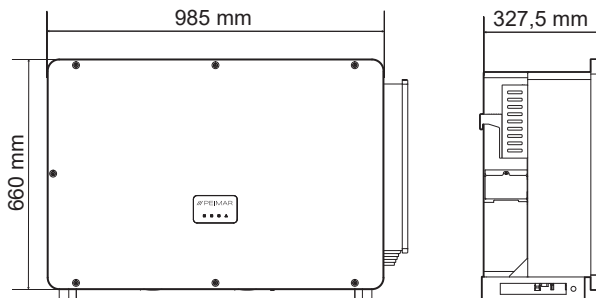

2.4. Packing list

Specifics	Quantità
Inverter	1
Support bracket	1
Positive DC connectors	24
Negative DC connectors	24
Positive DC pin connectors	24
Negative DC pin connectors	24
Protective AC shell	1
M8 screw	2
M10x40 screw	4
COMM connector	1
Allen key	1
Installation manual	1
Wi-Fi module PSI-X-H-ETH-3.0	1



Content control

Although Peimar inverters have passed rigorous checks and are tested before they leave the factory, it is not excluded that they may suffer damage during transport. Please check that the packaging has not shown any obvious signs of damage; in the event that such evidence occurs, please do not open the box and contact your dealer as soon as possible.

3. Installation hypothesis



DANGER

Before installation, make sure that there are no active electrical connections and make sure, before drilling the wall, that there are no pipes from other systems passing through. Danger to life due to risk of fire or electric shock.

Do not install the inverter near flammable or explosive objects.

This inverter will be directly connected to a HIGH VOLTAGE electric generator; installation must be carried out only by qualified personnel.



NOTICE

This device is compatible with environmental pollution degree II for outdoor environment. An inappropriate or non-compliant installation environment may compromise the life of the inverter. It is not recommended to install the inverter with direct exposure to sunlight. The installation site must be well ventilated

3.1. Packing check

Although Peimar inverters have passed rigorous checks and are tested before they leave the factory, it is not excluded that they may suffer damage during transport. Please check that the packaging has not shown any obvious signs of damage; in the event that such evidence occurs, please do not open the box and contact your dealer as soon as possible.

3.2. Place of installation

This device is compatible with environmental pollution degree II for outdoor environment. The inverter has an IP66 degree of protection, so it can also be installed outdoors, but with the appropriate precautions: an inappropriate or non-compliant installation environment can compromise the life of the inverter.

- Do not expose the inverter to direct sunlight as this may cause power derating due to overheating.
- It is not recommended to install the inverter with direct exposure to rain, excessive humidity or other bad weather.

- The installation site must be well ventilated.
- The installation site must be away from corrosive, flammable or explosive substances.
- The place of installation must be far from antennas or electrical devices for the transmission and/or reception of electromagnetic waves.
- The installation site must be at an altitude of less than 4000 m.
- The ambient temperature should be between -25°C e $+60^{\circ}\text{C}$.

3.3. Methods of installation and placement

Make sure that the inverter installation wall has sufficient strength to support the weight.

Do not place the inverter with the input/output terminals in contact with other surfaces, as these are not designed to support the weight of the inverter. Always place the inverter horizontally during the installation phases.

1. Please install the device as shown in the figure below. Vertical installation is recommended, or with a maximum inclination of 5° backwards. Never install the inverter tilted forward or sideways, horizontally or upside down. The inverter must be installed at least 500 mm from the ground.

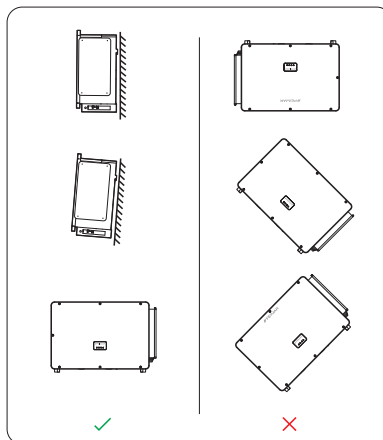

2. Install the inverter at eye level to facilitate viewing of the display and the possible maintenance activities.

3. Carry out the installation of the inverter providing for the possibility of disassembly for any maintenance works. Also make sure there is free space around the device to ensure ventilation, as shown in the figure below:

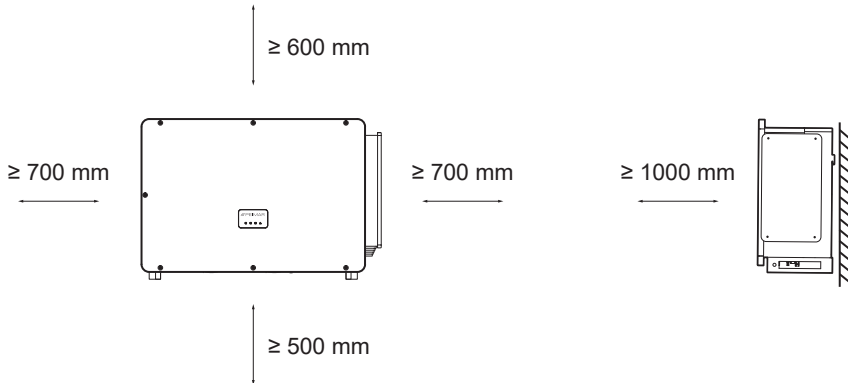

For an installation of several inverters, leave a lateral space of at least 1200 mm between the inverters and a space of at least 500 mm above and below.

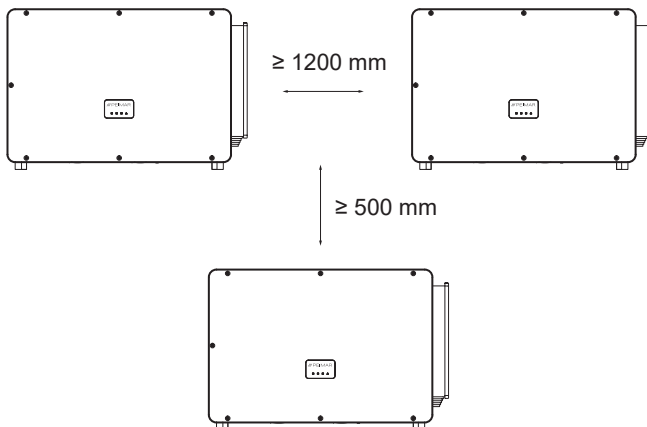

3.4. Assembly procedure

Provide yourself with the useful material and the contents of the package to start fixing.

1. Mark the position of the drilling points for mounting the anchor bracket.
2. Drill the necessary holes ($\Phi 13$ and at least 65 mm deep) in the wall at the marked points and insert the wall plugs using a rubber hammer.
3. Fix the anchor bracket to the wall, screwing the M8 screws into the wall plugs.

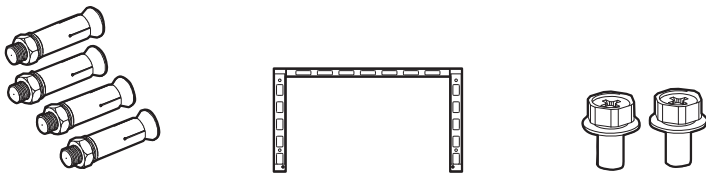

4. Carefully attach the inverter to the bracket, ensuring that the back of the device is mounted tightly against the bracket. Given the considerable weight, handle the inverter with two people, or use lifting rings.

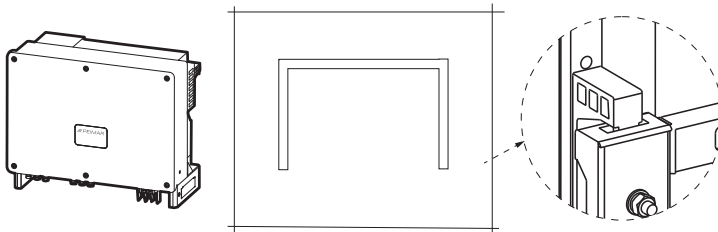

5. Place the inverter on the guide and tighten the two screws on the side to ensure correct fixing.

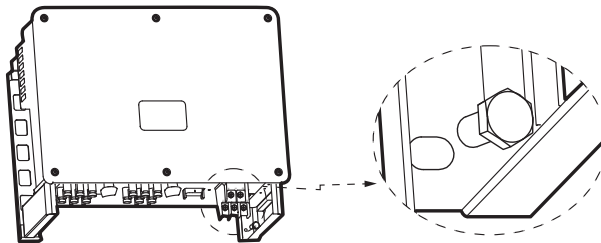

4. Installation hypothesis

Configuration of a PSI-X3P-TPM series three-phase network inverter.

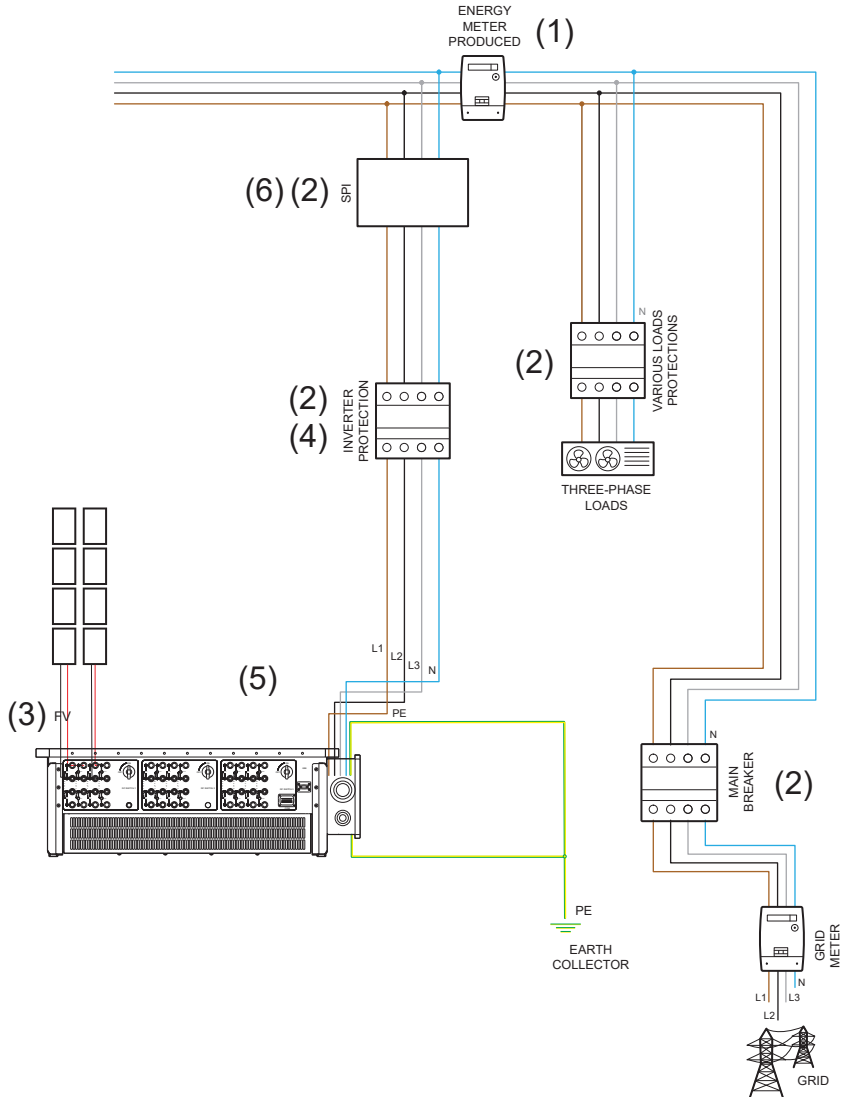

1. The position of the energy meter indicated in the diagram is purely indicative and to be evaluated in agreement with the project planner on the basis of the regulations in force at the time of installation and of any other existing systems.
2. The protections indicated on the diagram and their position are purely indicative and to be evaluated in agreement with the project planner on the basis of the regulations in force at the time of installation and of any other existing systems.



PLEASE NOTE

Peimar does not provide the protections described in this document. Contact your distributor to purchase.

3. For correct operation of the inverter, make sure that the voltage and current compatibility between the inverter and the photovoltaic strings are respected.
The inverters have two parallel connected DC inputs for each MPPT. It is not necessary to connect both strings, but if the configuration chosen for the system requires, they must be equal to each other. It is recommended to use all the MPPTs of the inverter. For more details, see the chapter on PV connections in this manual.
4. For safety and in compliance with the regulations, anticipate the installation of a magneto-thermal differential switch downstream of the AC side output, with a differential of at least type A and an intervention threshold $I_{dn}=0.3$ A. Size the line AC according to the distance between the inverter and the exchange meter. For more details, see the chapter on AC connections in this manual.
5. The project planner will evaluate the need to install any additional external dischargers, with respect to the overvoltage protection devices (SPD) already supplied with the inverter, for the protection of the PV side and AC side circuits. For more details, refer to the PV and AC connections chapter of this manual.
6. For systems with a nominal power greater than 11.08 kW, anticipate the installation of an external interface protection system, as required by the legislation.

5. Electrical connection

5.1. Connection inputs for the inverter

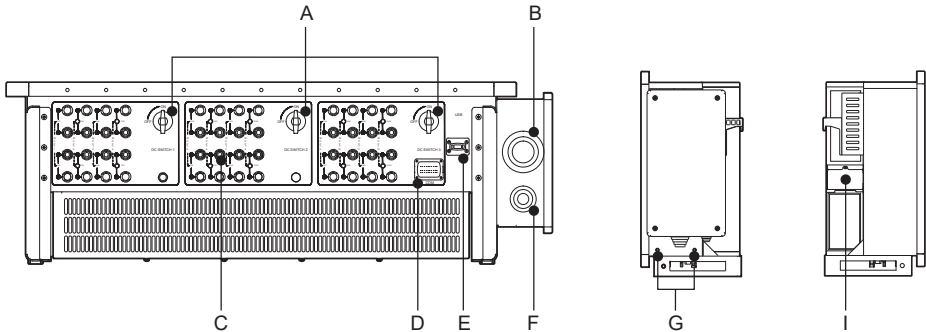

The inverter in this photo is the PSI-X3P125000-TPM

- | | |
|---|---|
| A | DC disconnectors |
| B | AC Connector |
| C | DC connectors of the mppts |
| D | RS 485 / Meter / DRM Connector (Optional connections) |
| E | Input for Wi-Fi/Ethernet/4G Dongle module connection |
| F | Earth connection |
| G | Ground screws |
| I | Cooling fan |

5.2. PV connection

Before proceeding with the connections, it is advisable to pay attention to the following technical requirements:

- It is important to connect only modules with the same electrical characteristics (same model of the panel) and same orientation and exposure to the sun on the same string.
- If there are panels with different electrical characteristics (different models; different number of modules in series; different orientation; etc.) it is necessary to use independent MPPTs which act separately.

For correct operation of the inverter, make sure that the voltage and current compatibility between the inverter and the photovoltaic strings are respected. Therefore:



NOTICE

Make sure that the voltage and current of the strings do not exceed those at the inverter input; an incorrect configuration can cause permanent damage to the inverter, which will not be included in the warranty:

V_{oc_Tmin} (Open circuit voltage at minimum temperature) < V_{max_cc} (maximum DC voltage)

V_{mp_Tmin} (Voltage at P_{max} at minimum temperature) < V_{max_mppt} (MPPT maximum voltage)

V_{mp_Tmin} (Voltage at P_{max} at minimum temperature) < V_{max_sis} (maximum panel system voltage)

I_{mp_Tmax} (Current at P_{max} at maximum temperature) < I_{max_mppt} (maximum MPPT current)



NOTICE

Make sure that the string voltage is higher than the inverter start-up voltage or the system may not turn on or have poor efficiency:

V_{oc_Tmax} (Open circuit voltage at maximum temperature) > V_{start} (startup voltage)

V_{mp_Tmax} (Voltage at P_{max} at maximum temperature) > V_{min_mppt} (minimum voltage of the MPPT).

The positive and negative PV inputs are located on the underside of the inverter. The use of all MPPTs is recommended in order to make the most of the inverter.

1. It is possible for each MPPT to connect only one string, it is not necessary to use both DC inputs.

MODEL 100 KW

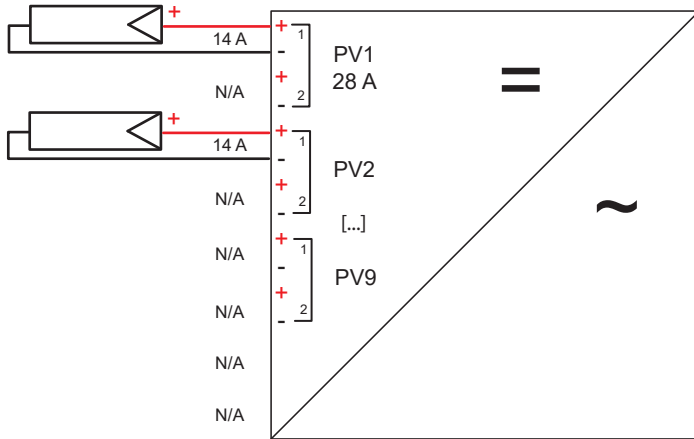

MODEL 125 KW

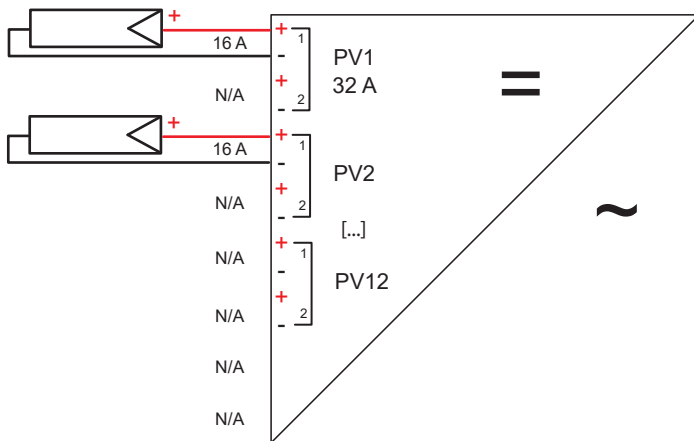

- The maximum current on each output is 14A (for X3P-100000TPM model) and 16A (for X3P-125000TPM model). In case of a string with a current greater than 14 or 16 A, it is necessary to use Y connectors as shown in the figure.

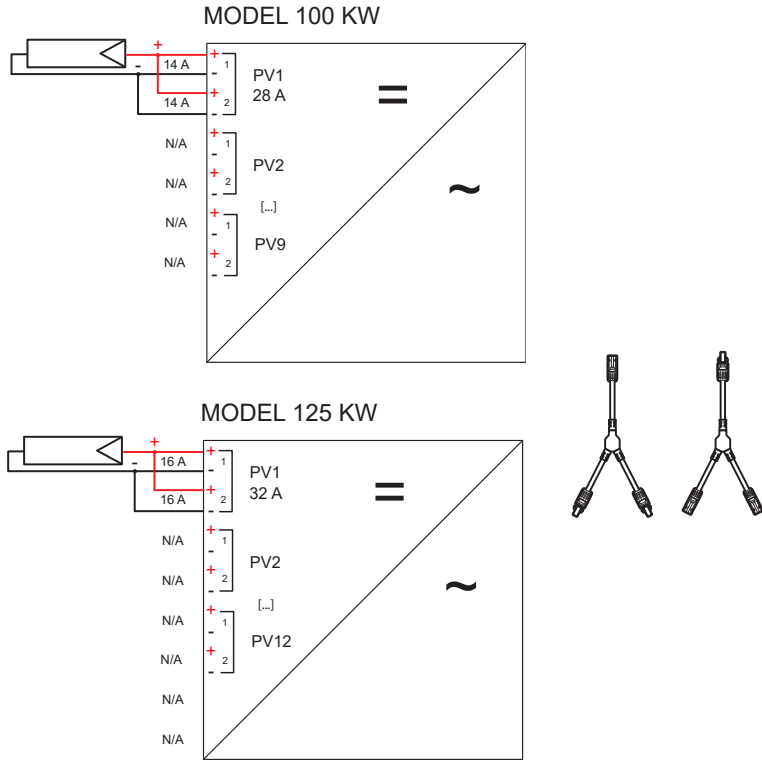

- The strings can also be connected to more than one MPPT for example, through the use of a parallel panel, in order to have a greater maximum input current.



PLEASE NOTE

The diagrams shown as an example in the photos refer to an example with 4 mppts connected, but this also remains valid for the remaining MPPTs of the inverter; in case of parallel MPPT, therefore in case of activation of the Multi/Comm function, all the MPPT of the inverter must be connected in parallel.

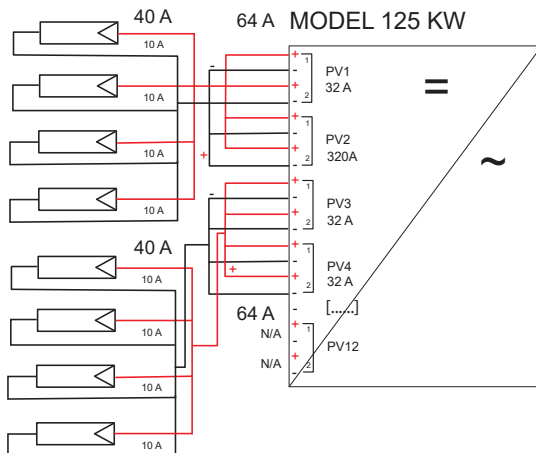
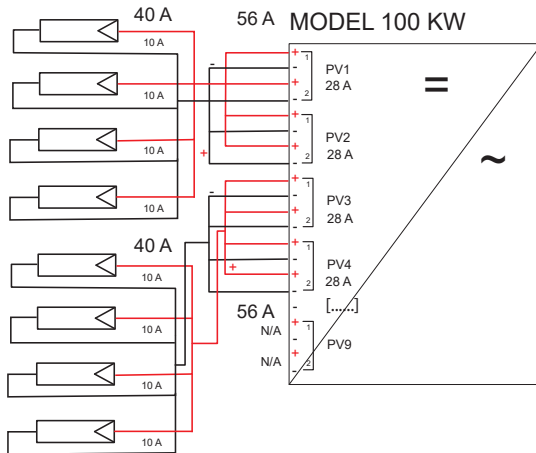

- In the event of more than two strings connected in parallel, but with a maximum current of less than 32A, assume the use of a parallel switchboard as shown in the figure.

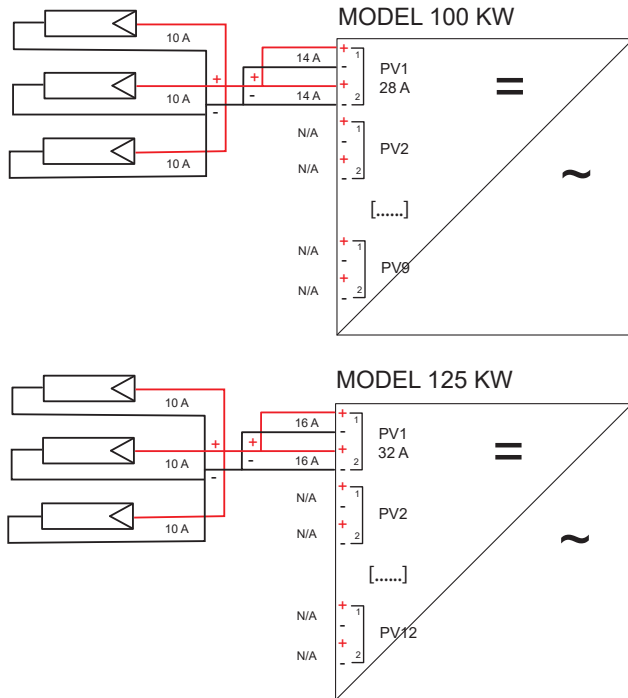

PLEASE NOTE

If a photovoltaic configuration with strings in parallel is expected, the parallel MPPT function must be set using the following procedure:

MENU > OPTIONS (PASSWORD "2014") > PV CONNECTION > MULTI/COMM.

The MULTI option is to be selected if the MPPTs are used independently (SCHEMES 1,2,4), the COMM option is to be selected if the MPPTs are put in parallel with each other (SCHEME 3).

The inverter has built-in overvoltage protection via type II SPD; The project planner, on the basis of the risk of lightning and what is required by current legislation, will evaluate the need to install any additional external arresters with respect to the type II SPDs already supplied with the inverter, for the protection of the photovoltaic side circuits

To connect a photovoltaic string to the inverter, two solar cables are required which are in turn connected to the positive and negative DC inputs of the inverter. The cables on the inverter side, use the connectors provided in the package. The cables on the side of the panels, obtain the appropriate MC4 or compatible connectors (see diagram below).

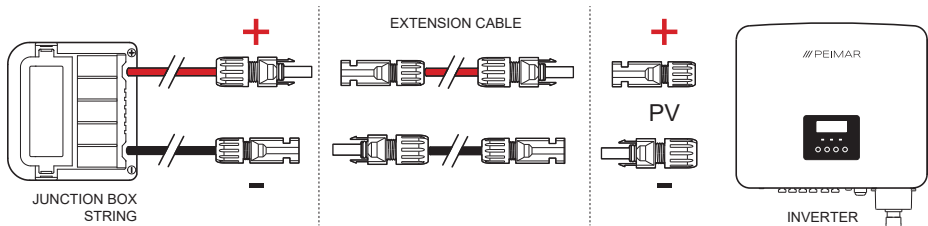

PLEASE NOTE

Peimar does not supply the solar cables and MC4 connectors from the side of the panels described above in this document. Contact your distributor to purchase.

DC connection procedure.

For the DC connection, observe the following assembly procedure:

1. Before connecting the photovoltaic strings to the inverter, make sure that the DC switch of the inverter is turned OFF.
2. Take the positive and negative MC4 connectors from the package, including the waterproof gasket, locking ring nut and metal pin, which will be mounted on the string terminals to make the connection with the inverter.

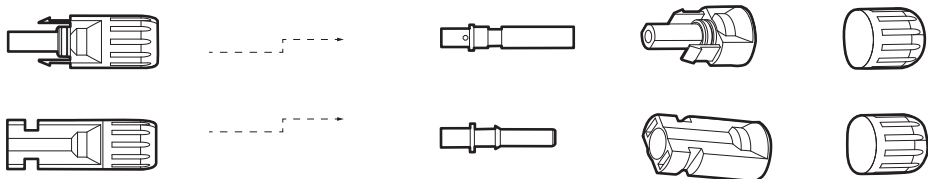

- Strip the ends of the cables connected to the photovoltaic string by about 6 mm and crimp the metal pin of the MC4 connectors with pliers, paying attention to respect the polarities. The recommended section of the photovoltaic cable is 4-6mm². Then tighten the stripped cable, insert it into the pin contact and crimp it.

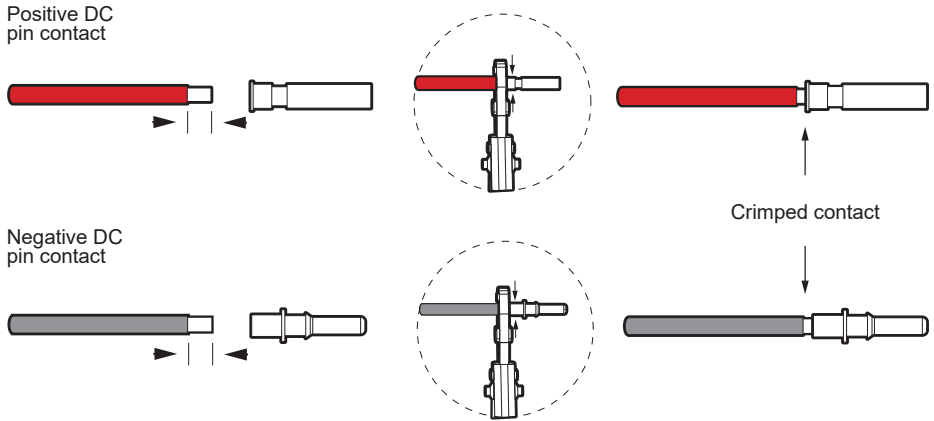

- Insert the locking ring nut and the waterproof gasket of each MC4 connector on the photovoltaic string cables; you will hear a "click" indicating that the connection is complete. Finally screw the locking nut onto the plug.

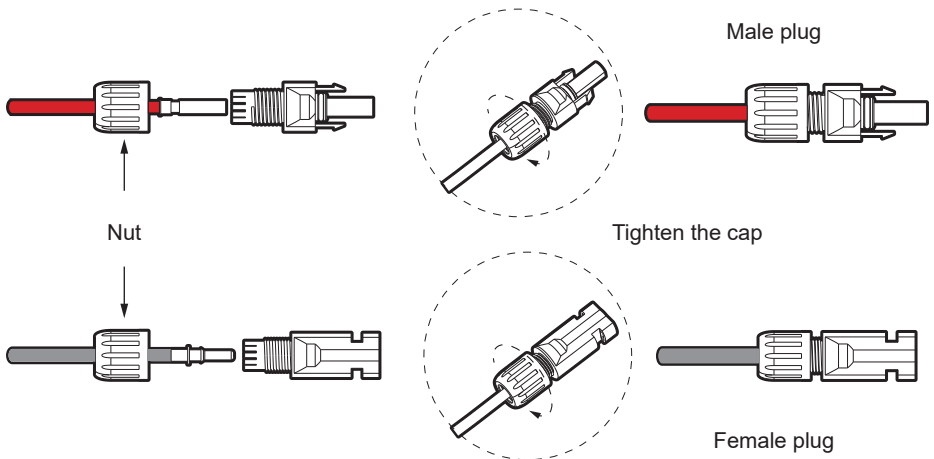

5. Check the voltage of the photovoltaic DC input with a multimeter, check the polarities of the DC cable and make sure that the voltage of each string is within the inverter range. Connect the positive and negative connectors (always respect the polarities) into the respective DC input terminals of the inverter as shown in the photo.

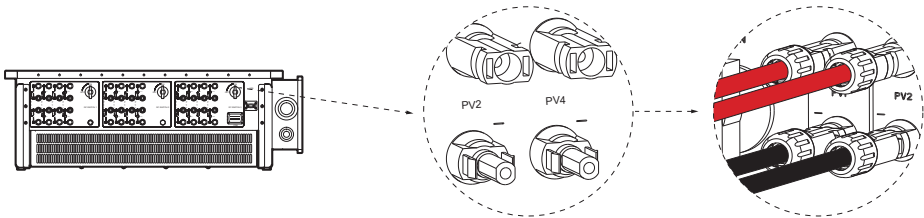

PLEASE NOTE

It is recommended to use a suitable tool during assembly operations and disassembly of the MC4 connectors, to avoid the risk of damaging them.

5.3. AC Connection

For connection to the alternating line, follow the instructions of the local public network.

For safety and in compliance with the regulations, provide for the installation of a magneto-thermal differential switch downstream of the AC side output, with a differential of at least type A (a type A or F differential is recommended) and an I_{dn} tripping threshold =0.3A.



PLEASE NOTE

Direct connection of any loads is not recommended, without the presence of adequate protections.

Size the AC line according to the distance between the inverter and the exchange meter; if the distance is very high, please increase the cable section to avoid excessive voltage drops. The use of cables with a diameter of 70-240 mm² is recommended.

The inverter has built-in overvoltage protection via type II SPD;

The project planner, on the basis of the risk of lightning and what is required by current legislation, will evaluate the need to install any additional external arresters with respect

to the type II SPDs already supplied with the inverter, for the protection of the alternating current side circuits.

Check that the voltage arriving from the grid is compatible with the voltage supported by the inverter.

AC connection procedure.

For AC connection observe the following assembly procedure:

1. Make sure you have cut off the AC side power.
2. Take the AC line connector out of the package.
3. Prepare the AC line wires of the appropriate size, strip the ends of them about 2-3 mm more than the "D" part of the OT terminal.

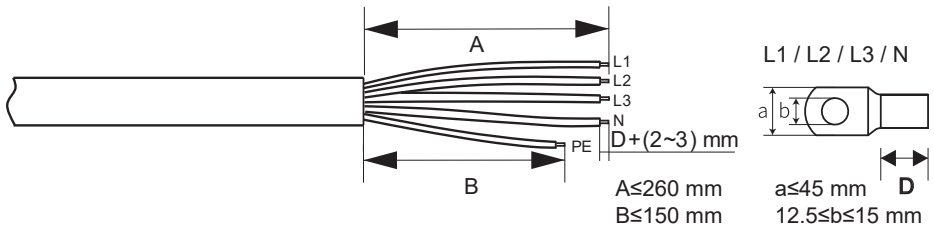

4. Provide a heat shrink to insert on the AC cable.
5. Place heat shrink tubing over the AC wire and wires with the OT connectors once crimped. Then heat shrink tubing to secure the connectors.

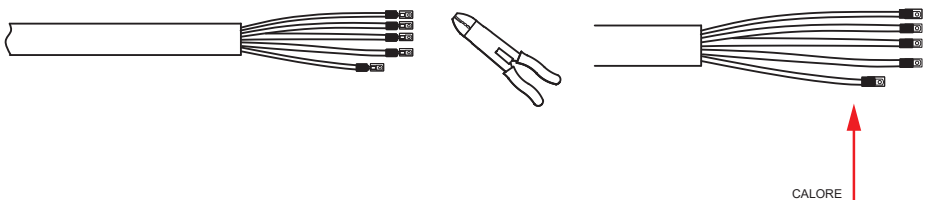

PLEASE NOTE

The default "Delta Grid" function is set to "Enabled" and the Neutral cable is not to be connected. To connect the neutral choose "Disable" on the "Delta Grid" function".

To change the settings go to

MENU > "SETTINGS" > PASSWORD "2014" > "CONTROLS" > "DELTA GRID".

5. Open the cover of the AC connection box on the inverter.

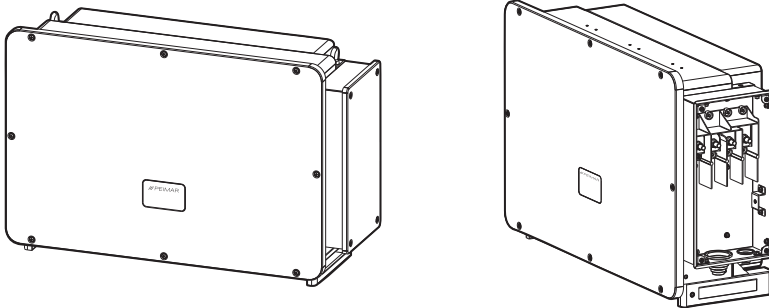

6. Cut the existing rubber protector according to the size of the AC cable and insert the cable until the cables match the correct pins on the inverter terminal block. Connect the pins with the corresponding L1,L2,L3,N and PE terminals. Then tighten the screws until snug (see photo below for the types of AC cord used).

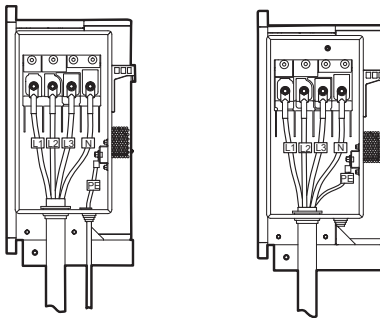

7. Reinstall the AC connection box cover when the job is complete.

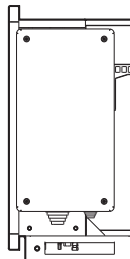

5.4. Meter connection

5.4.1. Meter PSI-X-3PMETER-HY

The meter is a device that allows you to analyze the energy flow of the system to manage it appropriately; the meter is compatible with three-phase inverters of the PSI-X3P (TP-TPM-HY) and PSI-X3S (HY) series for currents up to 80A is the PSI-X-3PMETER-HY with direct connection.

The meter also allows you to set the "Export Control" function which defines the power transferred to the grid. By default, the energy produced that is not self-consumed by the plant will be fed into the grid; if the user does not want to transfer power to the grid, he will have to set the value "0 Watt" in the advanced options of the inverter.

The Meter must be installed upstream of all network loads, downstream of the exchange meter; refer to the diagram below (the position of the energy meter produced and of the protections indicated in the diagram are purely indicative and to be evaluated in agreement with the project planner on the basis of the regulations in force at the time of installation and of any other existing systems):

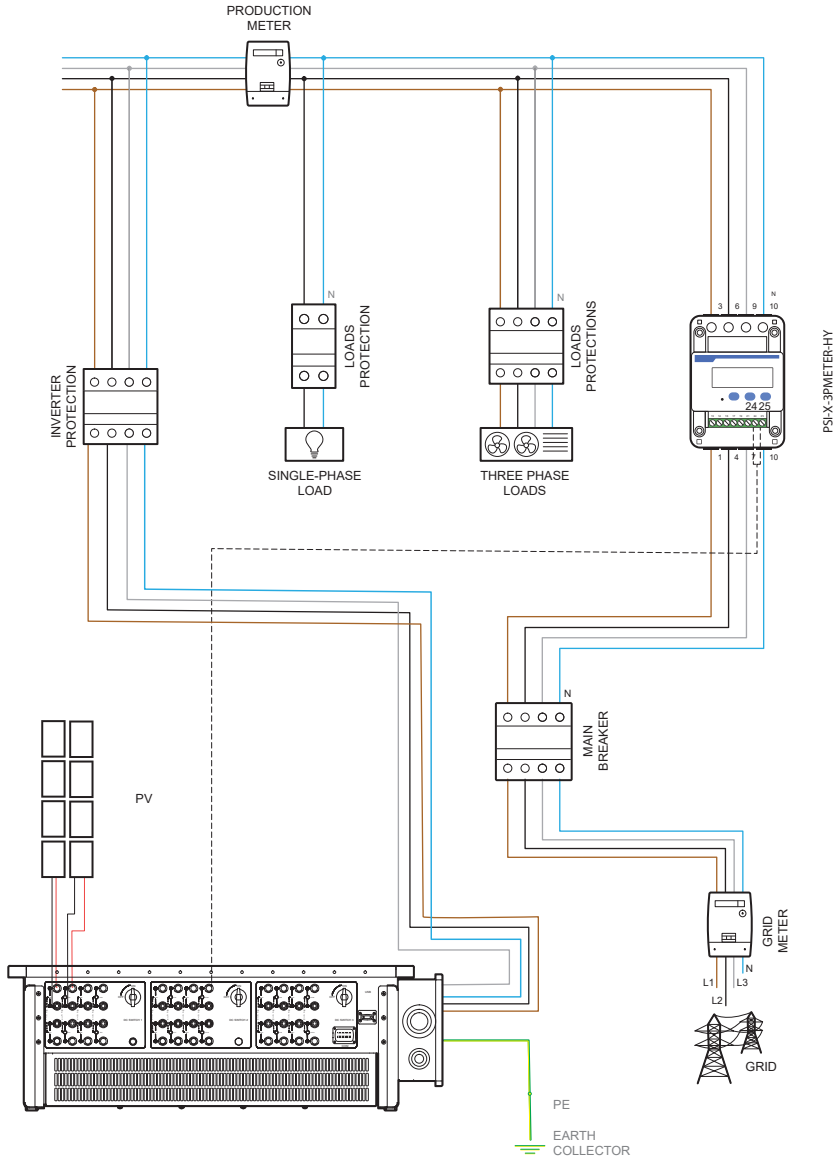

For the connection of the PSI-X-3PMETER-HY meter observe the following assembly procedure:



NOTICE

Make sure you have cut off the AC side power on the utility line.

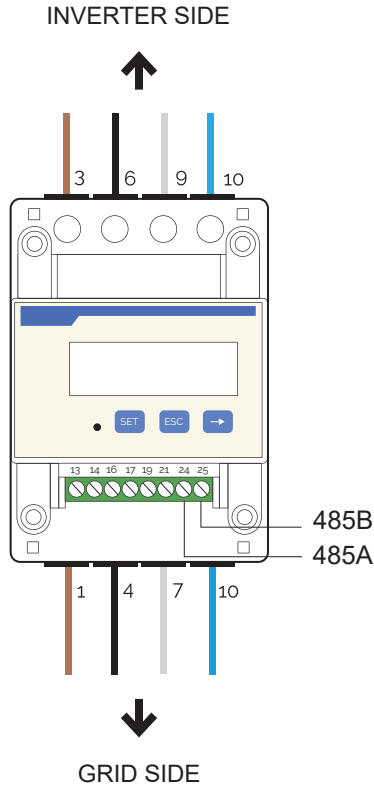

1. Strip the three phases arriving from the exchange meter (mains side) by 8-10 mm and attach them respectively to inputs 1, 4 and 7 of the meter by tightening the terminal.

2. Strip the three phases arriving from the grid (inverter side) by 8-10mm and fix them respectively to output 3, 6 and 9 of the meter by tightening the terminal.
3. Strip the neutral cables arriving from the exchange meter (grid side) and from the system (inverter side) by 8-10 mm and secure them to input 10 both at the input and at the output.
4. Lay a twisted-pair cable long enough to span the distance between the inverter and the meter (a 10m cable is included in the package). Insert the two wires of a terminal into outputs 24 and 25 of the meter and fix them by tightening the clamp.
5. For the connection on the inverter side, refer to the manual of the specific model (see paragraphs below).
6. Once the electrical connection phase has been completed, fix the PSI-X-3PMETER-HY meter on 35 mm guides. Since the meter is neither waterproof nor dustproof, it is recommended to install it inside the electrical panel.
7. The display of the PSI-X-3PMETER-HY meter lights up when voltage is supplied to the system.
8. The meter is already automatically set with the correct network parameters; by briefly pressing the "arrow" key it is possible to scroll and check the various parameters.

5.4.2. Meter PSI-X-3PMETER-HY-CT

The meter compatible with the three-phase network inverters described here for currents up to 200 A is the PSI-X-3PMETER-HY-CT.

The meter also allows you to set the "Export Control" function which defines the power transferred to the grid. By default, the energy produced that is not self-consumed by the plant will be fed into the grid; if the user does not want to transfer power to the grid, he will have to set the value "0 Watt" in the advanced options of the inverter.

The Meter must be installed upstream of all network loads, downstream of the exchange meter; refer to the diagram below (the position of the energy meter produced and of the protections indicated in the diagram are purely indicative and to be evaluated in agreement with the designer on the basis of the regulations in force at the time of installation and of any other existing systems):

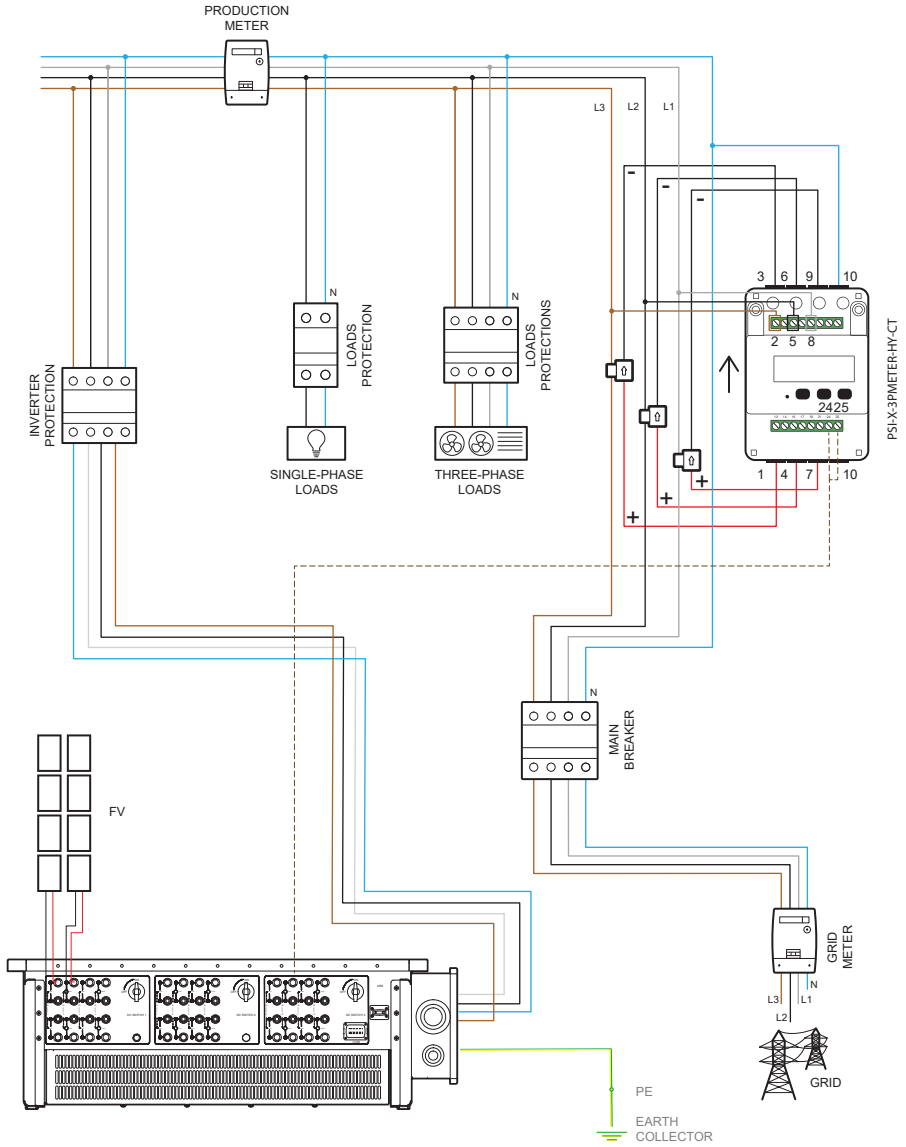

For the connection of the PSI-X-3PMETER-HY-CT meter observe the following assembly procedure:



NOTICE

Make sure you have cut off the AC side power on the utility line;

TOWARDS THE CT

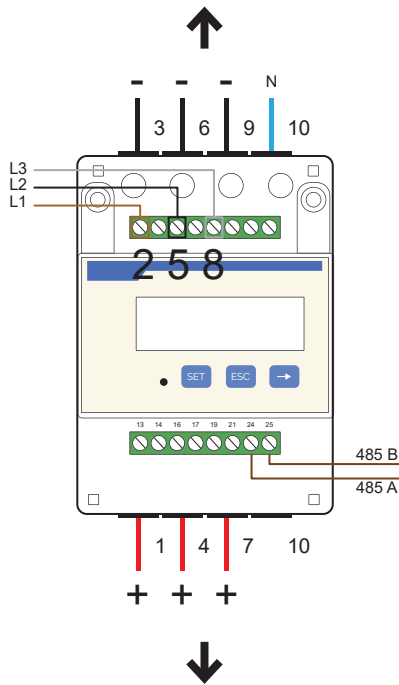

TOWARDS THE CT

1. Create a derivation of the three phases arriving from the exchange meter, strip them 8-10mm and fix them respectively to inputs 2, 5 and 8 of the meter by tightening the terminal; the cable should have a section of 0.25~1 mm² (17~23AWG).

2. Fix the positive cable (red) of the first CT to output 1 of the meter and the negative cable (black) to output 3; fix the positive cable (red) of the second CT to output 4 of the meter and the negative cable (black) to output 6; secure the positive (red) cable of the third CT to output 7 of the meter and the negative (black) cable to output 9.
3. Strip the neutral cable arriving from the exchange meter (mains side) of 8-10 mm and fix it to input 10.
4. Position the 3 CT's, hooking them around the cables of the three phases, paying attention to the direction of the arrow (the arrow on the CT must point towards the inverter). Check the correspondence of the wiring of the different lines:
 - The CT connected to ports 1 and 3 must be hooked around the line cable connected to port 2 of the meter (L1 sull'immagine).
 - The CT connected to ports 6 and 4 must be hooked around the line cable connected to port 5 of the meter (L2 sull'immagine).
 - The CT connected to ports 7 and 9 must be hooked around the line cable connected to port 8 of the meter (L3 sull'immagine).

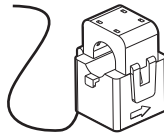

5. Lay a twisted-pair cable long enough to cover the distance between the inverter and the meter (a 10m cable is included in the package). Insert the two wires of a terminal into outputs 24 and 25 of the meter and fix them by tightening the clamp.
6. For the connection on the inverter side, refer to the manual of the specific model (see paragraphs below).
7. Once the electrical connection phase has been completed, fix the PSI-X-3PMETER-HY-CT meter on 35 mm guides. Since the meter is neither waterproof nor dustproof, it is recommended to install it inside the electrical panel.
8. The display of the PSI-X-3PMETER-HY-CT meter lights up when voltage is supplied to the system.
9. The meter is already automatically set with the correct network parameters; by briefly pressing the "arrow" key it is possible to scroll and check the various parameters.

Inverter connection.

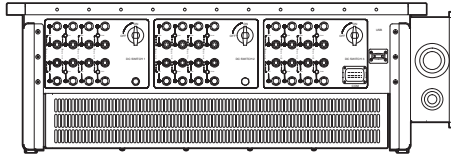

RS-485-2	7	RS485A METER	Connect the RS485 meter or other devices.
	8	RS485B METER	

Connection

- a) Take the communication terminal out of the box and separate the respective parts as shown.

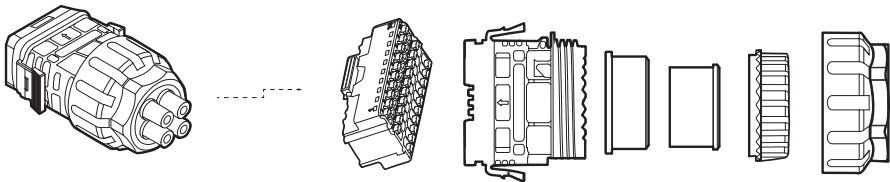

- b) Take a communication cable, strip two wires of 12-14 mm and connect them to PIN 7 and PIN 8 of the 30 PIN housing.

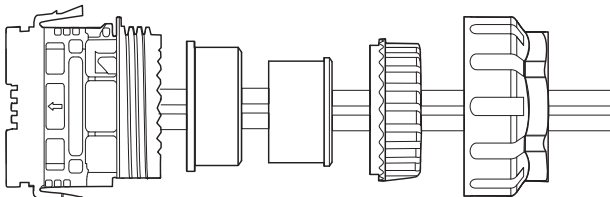

- c) Then insert the head of the connector until you hear a "Click" which indicates that it has been hooked up.

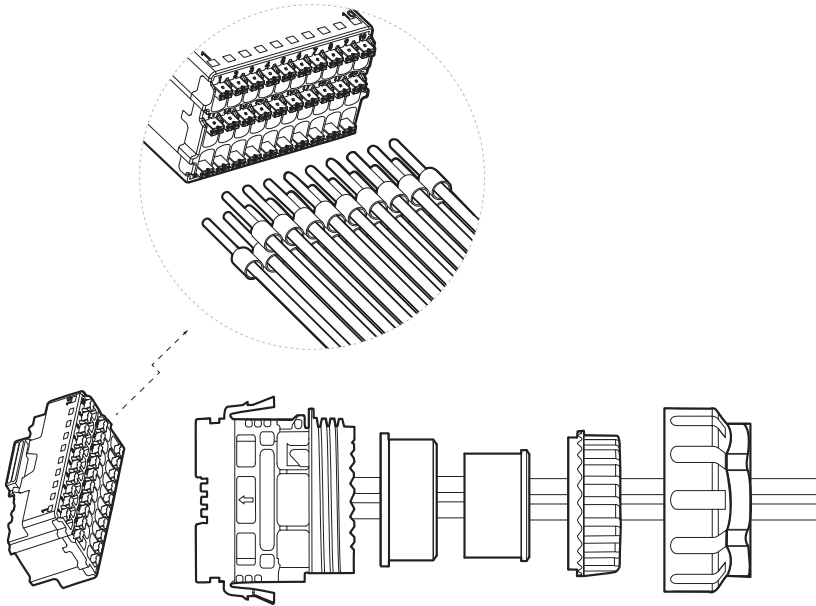

- d) Push the connector body onto the sealing ring and then insert the nut.
- e) Screw the ring nut until tight.
- f) Insert the connector thus assembled into the COM Port of the inverter.

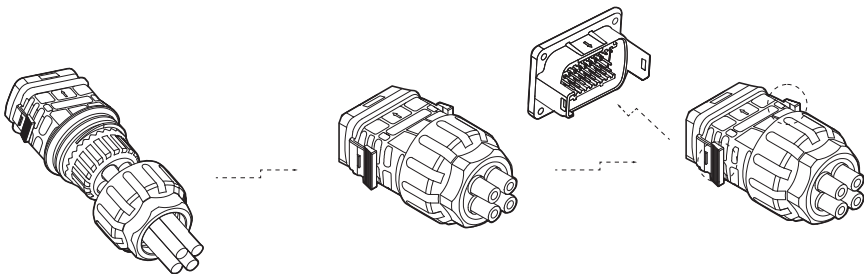

To unplug the connector, once mounted on the inverter, press the side buttons at the same time.



PLEASE NOTE

Crimp the two wires of the other end of the cable to the meter, so that there is continuity between:

- Terminal 24 of the meter and Pin 7 (RS485A) of the plug.
- Terminal 25 of the meter and Pin 8 (RS485B) of the plug.

See diagram below.

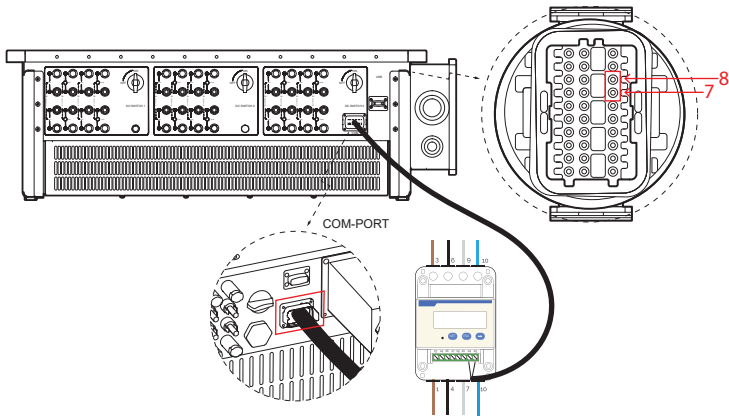

6. Earth connection

For the safety of the system, it is mandatory to earth the inverter. In case of more devices, each one must be connected to earth. For fixing, follow the procedure below:

1. Take the copper OT connector and the green and yellow earth wire of the suitable length and size (diameter 35-75 mm²).
2. Strip the ground wire, crimp the OT connector and put the heat shrink;

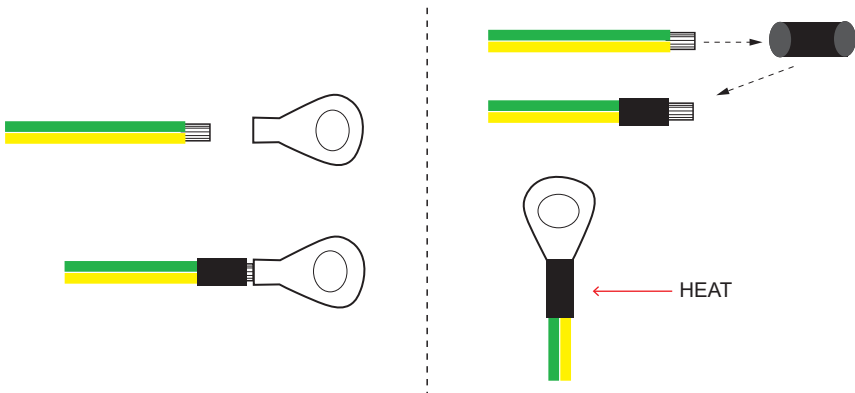

3. Finally, secure the earth cable in the special hole on the inverter, identified by the earth symbol, by tightening the hexagonal head screw already screwed to the dissipator.

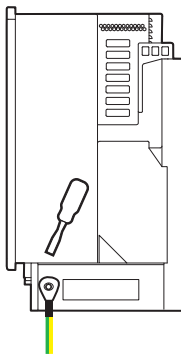

7. Parallel connection of multiple PSI-X3P-TPM series inverters

This chapter describes the parallel connection of several inverters of the PSI-X3P-TPM series, respectively with an output of 100 kW and 125 kW.

If it is not necessary to reduce the power fed into the grid or to read self-consumption, it is also possible to connect a greater number of inverters to the same three-phase line, without using the meter for energy management; it is however necessary to evaluate its feasibility with the project planner in compliance with current regulations.

If you want to connect several inverters in parallel, keeping the Meter to control the input/output of the energy into the grid, an external device must be used.

The external device is also necessary if you want to make the parallel connection between inverters of the PSI-X3P-TPM series with a power of 100 kW and 125 kW respectively and other models of the PSI-X3P series.



PLEASE NOTE

To be able to make this connection, please contact the manufacturer, in order to have specific technical information.

For systems with a rated power greater than 11.08 kW, the installation of an external interface protection system must be provided, as required by the regulations.

8. Starting the inverter

Before turning on the inverter, pay attention to the following:

1. Make sure the inverter is properly fixed to the wall.
2. Make sure the DC and AC switches on the inverter are in the "OFF" position.
3. Make sure the AC wire is properly connected to the network.
4. Verify that the DC and AC lines are properly connected.
5. Check that all photovoltaic panels are connected to the inverter correctly and that unused DC connectors are covered by the appropriate cover.



PLEASE NOTE

Before starting the inverter, make sure you have completed all the electrical connections correctly.

Inverter power-up procedure:

1. Be sure to turn on the DC and AC external protectors.
2. Turn the inverter DC line disconnect switch to On.
3. The inverter turns on automatically when the PV panels generate enough energy.
4. Verify that the LED status is Blue and that the LCD screen is in the main screen.
5. If the LED is not Blue check:
 - that all connections are correct;
 - that all external protections are closed;
 - that the DC switch of the inverter is set to "ON";

The correct start of the inverter is indicated in 3 different states:

- Standby: The inverter checks that the DC voltage is between a minimum of 160 V (lowest voltage value for the start phase) and a maximum of 220 V (lowest voltage to be able to operate).
- Check: the inverter will automatically control the DC input when the voltage coming from the panels exceeds 200V.
- Normal: the inverter starts working when the Blue light is on, and at the same time it transfers energy to the grid, showing its output power on the screen.

9. Setting and display interface

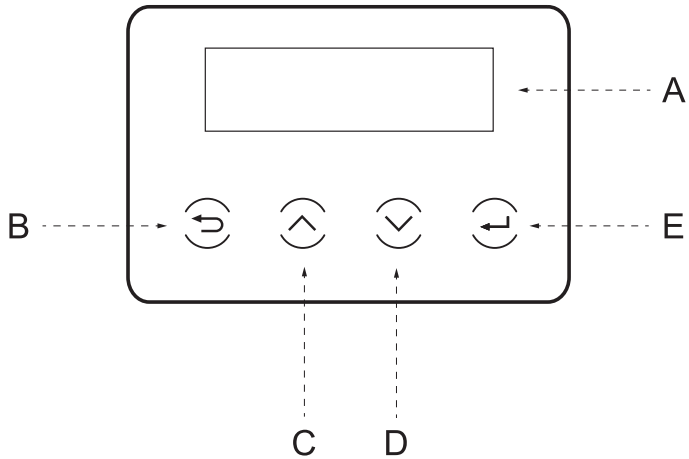

A	Display	The display allows the inverter production data to be viewed and the operating parameters to be set.
B	ESC button	Return to the previous screen or cancel the setting.
C	UP button	Move the cursor up or increase the set value.
D	DOWN button	Move cursor down or decrease set value.
E	Enter button	Enter the chosen option or confirm the selection.

10. Block diagram of the inverter screens

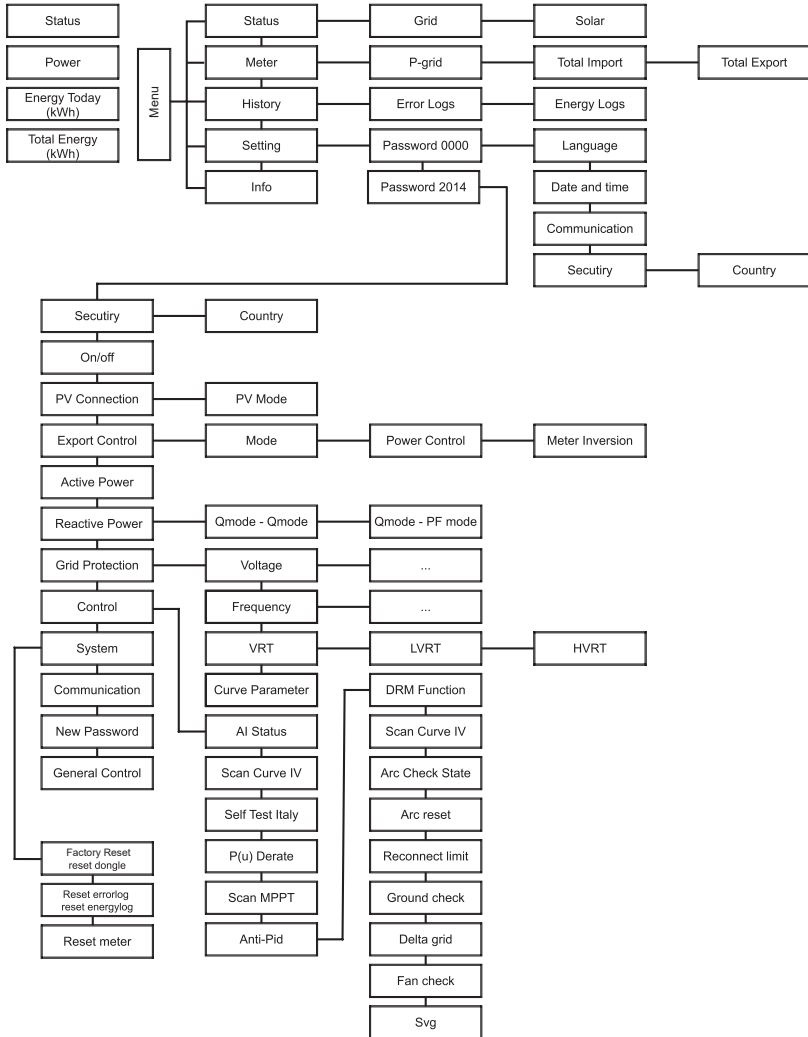

11. Main functions on display

When the inverter has started, the screen that appears on the display is the main one which shows the following information:

- "Status" = shows the current time and status between "Waiting", "Checking", "Running", "Error".
- "Power" = indicates the instantaneous output power.
- "Energy Today" = indicates the energy produced during the day.
- "Total Energy" = indicates the energy produced up to now.

(scroll with the up and down arrows to read the information on the display)

Menu

This screen is used for the user to view information relating to the inverter and change its settings. To enter this screen, press the "Enter" key on the inverter for a certain amount of time on the main startup screen.

Choose the desired settings by scrolling with the up and down arrows and press "Enter" to confirm.

In the menu we find:

Status

Two parameters are displayed: Grid and Solar.

a. Grid

Here it can be seen the current AC parameters of the inverter such as voltage, current, output power and grid power etc.

With "Pout" it measures the inverter output, "Pgrid" measures the active power. "Qout" measures the reactive power; "Sout" indicates the apparent power. Press up and down to view the various values and press Exit to return to Status.

```
=== Grid ===  
> Ua xxx.xxV  
Ia xxxx.xA
```

b. Solar

This interface shows the PV input current. It is possible to monitor the maximum current and voltage of 6 strings of the MPPTs of the inverter.

```

    === Solar ===
    > MPPT1_V xxxxV
    MPPT1_I xxxxA
    
```

Meter

The user can check the imported and exported energy with this function. There are 3 parameters: "Pgrid Power", "Total Import" and "Total Export". Press up and down to view the various values. If the Meter is not connected, the indicated parameters will show "0" on the screen.

History

"History" contains "Error Logs" and "Energy Logs".

"Error Log" contains the information of the errors occurred. It can record up to six errors. Press up and Down to scroll through the parameters and press Exit to return to the main screen. "Energy Log" contains the energy values generated during the day. Press up and down to scroll through the parameters and press Exit to return to the main screen.

```

    === Error Logs ===
    02/08 10:10:10
    Grid Lost
    
```

```

    === Energy Logs ===
    02/08
    XXXX K Wh
    
```

Settings

Use this screen to access and change inverter settings. To modify the parameters, the password must be entered. For end users, the default password is "0000" which, if entered, allows you to change "Language", "Date and Time", "Communication" and view the network standard. All other settings can only be viewed and changed by installers, using the password "2014".

a. Language

Your device already has default language and network standards set

b. Date and time

This function sets the date and time in the inverter. Use the up and down arrows to change the values.

c. Communication

RS485 Addr = indicates the modbus address of the external communication protocol.

RS485 Baud = indicates the Baud rate of the external communication protocol. To date, the values 4800, 9600 and 19200 are supported.

If you need to restore this data, the changes should be made based on your local grid requirements. With this function it will be possible to make the inverter communicate via an external device, for example a PC in order to monitor its status. When multiple inverters are monitored by a single PC, the RS485 communication addresses of the different inverters must be set.

=Communication Parameter= > RS485 Addr 1	= Communication Parameter = > RS485 Baud 9600
--	---

d. Safety

The end user can only view the standard security values of the country he belongs to. The installer can change the setting using the password "2014". Once the password has been entered, the information on the display is shown as below:

=== Settings === >Safety System ON/OFF
--

The installer can set the safety standard based on the regulations of the different countries and on the basis of the local public network. For example:

=== Safety === >country >VDE4105<



PLEASE NOTE

For inverters installed in Italy, the item CEI 0_21 is available in the list of standards with the parameters required by the current CEI 0-21 standard; only if the inverter is installed under the Areti - ACEA Group grid, please select the ACEA standard. The previous indications must be checked and confirmed by the network manager and by the technician who connects to the network.

e. **On/Off**

“On” the inverter is running, “Off” indicates that the inverter is off and only the display is active.

f. **PV connection**

User can select PV connection through this function. Multi option i > independent mppt COM >mppt in parallel.

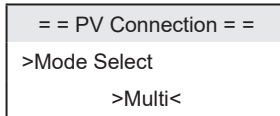

g. **Export control**

With this function, the inverter can control the energy fed into the grid by installing an external meter. The “Control Power” can be set by the installer. When the value is set to "100%" it means that all the energy is sent to the grid at full power. If "0" is set, the feed into the grid is limited. Set the value as needed. Choose "Disable", the function will be deactivated. Press up and down to select and Enter to confirm.

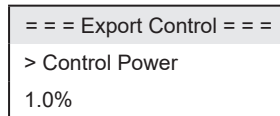

If the Meter is connected upside down, select the "Meter Inversion" option.

h. **Active power**

In this interface, the active power is set according to the local public grid.

i. **Reactive power**

In this interface you set the reactive power according to the local public grid.

j. **Grid protection**

In this interface you set the reactive power according to the local public grid. Typically the end user does not need to set up network protection. All default values have been set before leaving the factory in accordance with safety regulations. If, restore of this data is required, the changes should be made according to local network requirements.

```
=== Grid Protection ===  
>Voltage
```

k. **Control**

This interface is used to activate the functions “AI Status”, “P(u) Derate”, “MPPT Scan”, “Delta Grid” etc.

l. **System**

Here you can perform factory resets, log error resets, dongles, meter resets and energy resets. Press for example “Reset Meter” and press enter to confirm.

m. **Communication**

Refer to “Communication” under “Settings” after entering the password “0000”.

n. **New Password**

Here you can set a new password for the user. Simply choose the entered letter using the Up and Down keys, press enter to move to the next letter and then put Set and press Enter to change the password.

Info

This interface displays inverter information, including serial number and firmware versions (master, slave, etc).

```
=== About ===  
Product Type  
PSI-X3P40000-TPM
```

12. Firmware version

You can check the inverter firmware version by following the respective paths below:

MENU > INFO > MASTER (XFORTH V005.00 and later).

13. Inverter monitoring system configuration

13.1. Installer account creation



PLEASE NOTE

For each system, the account of the end user (owner of the system) must always be created and subsequently, if desired, it is possible to add the system created to the installer account. Not vice versa.

To obtain an installer account, please send an email to assistance@peimar.com, entering the following data:

- Company name
- Reference email address
- Username (Characters other than letters, numbers, "@", "_", "." are not allowed, there must be no spaces)
- SN of the inverter
- Tracking SN printed on the Wi-Fi module
- Password

As soon as the credentials are received from Peimar technical assistance, it will be possible to log in from the link <https://www.peimar-psix-portal.com/#!/login> and possibly change the password.

To monitor the customer's system it will be necessary to go to:

Device management > New devices > + Add and enter the monitoring SN of the Wi-Fi module, then press "Accept". If the whole procedure has been followed correctly it will be possible, after a few minutes, to observe the production data of the customer's photovoltaic system.

13.2. Configuration via Wi-Fimodule

In many models of the PSI-X series (single-phase grid inverter PSI-X1P-TL/TLM \geq 2kW, three-phase grid inverters PSI-X3P-TP, hybrid inverters PSI-X1P-HY PSI-X3PHY and PSIX3S-HY) a Wi-Fi module (PSI-X-H-WIFI or PSI-X-H-WIFI-3.0) is included which allows, if configured correctly, remote monitoring of operational status and data of production.



PLEASE NOTE

- If the SN of the module starts with SWxxxxxxx it is possible to carry out the connection procedure only via browser;
- If the SN of the module starts with SXxxxxxxx or SVxxxxxxx it is possible to carry out the connection procedure both via browser and via App.
- It is recommended to connect to the main Wi-Fi line since connection to repeaters/WiFi does not guarantee the sending of data to the server.

13.2.1. Configuration via browser Wi-Fi module

Connection procedure

1. Insert the Wi-Fi module into its USB port on the bottom of the inverter (WIFI for PSI-X3P-HY series inverters, Upgrade/Dongle for PSI-X1P-HY and PSI-X3S-HY series inverters , DONGLE for the inverters of the PSI-X1P-TL/TLM and PSIX3P-TP/TPM series); the LED located on the back will start flashing (LED not present in the PSI-X-H-WIFI-3.0 model).
2. Use a laptop or smartphone and look for the device's Wi-Fi hotspot which is generally called Wifi_Sxxxxxxx (Sxxxxxxx=code printed on the Wi-Fi module itself).

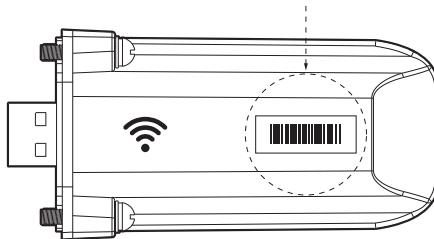

3. Connect permanently to the hotspot, click on "connect" and wait for confirmation (it is normal for the internet connection failure notice to appear).
4. Open the browser and type in the address bar <http://192.168.10.10/>.

**PLEASE NOTE**

For older inverter models, which have a PSI-X-H-WIFI stick (or for PSI-X-H-WIFI-3.0 sticks with SN starting with SX) use the address <http://5.8.8.8/> (Normally it is sufficient to type in the address bar 5.8.8.8) Be careful not to connect to the address <https://5.8.8.8/>

5. Insert username "admin".
6. Insert a password:
 - "Admin" if the SN of the module starts with SWxxxxxxx
 - Code printed on the module itself if the SN of the module starts with SXxxxxxxx or SVxxxxxxx.
7. Enter the "Setting Page" click on the "Find AP" button to scan the available Wi-Fi networks.
8. Select the home Wi-Fi network, enter the relative password in the "Key" box and click on "Save".

**PLEASE NOTE**

Network name and password must contain only numbers or letters, no special characters are Accepted.

9. The LED of the module, where present, will start flashing rapidly; when after about 20 seconds it becomes permanently on, it means that the Wi-Fi module has connected to the router.
10. Reconnect to the dongle.
11. Reconnect to the http address given above. Check that the data entered remained stored correctly and that there is the IP address so as to make sure that the connection was successful.

End user account creation**PLEASE NOTE**

For each system, the account of the end user (owner of the system) must always be created and subsequently, if desired, it is possible to add the system created to the installer account. Not vice versa.

Once the monitoring system has been successfully configured, type in the address <https://peimar-psix-portal.com/#!/login> to create a new end user account by pressing the "Sign up" button.

Create new user ●

* SN for tracking	<input type="text" value="Insert device's serial number"/>
* Username	<input type="text"/>
* Password for accessing	<input type="password"/>
* Confirm the password	<input type="password"/>
* Status	<input type="text" value="Please select"/>
* Time zone	<input type="text" value="Please select"/>
* Plant power (kW)	<input type="text"/>
* Email	<input type="text"/>
Username	<input type="text"/>
Telephone	<input type="text"/>
* Position	<input type="text"/>

In the field "SN Tracking" enter the code printed on the form itself and on the label applied to the box. All mandatory fields filled in (Italy time zone UTC +01:00), press the "Register" button to complete the registration.

Press the "Return" key and log in with the credentials you just created.

If the entire procedure has been followed correctly it will be possible, after a few minutes, observe the production data of the photovoltaic system.

13.2.2. Configuration via Wi-Fi module from app

Creating end user account



PLEASE NOTE

For each system, the account of the end user (owner of the system) must always be created and subsequently, if desired, it is possible to add the system created to the installer account. Not vice versa.

1. Download the Peimar X Portal App from the store



App Store



Google
Play Store

2. Choose the language clicking on the 3 dots at the top left.
3. Press the "Create new account" button, type or scan the tracking SN printed on the Wi-Fi module itself and press the "Next" key".

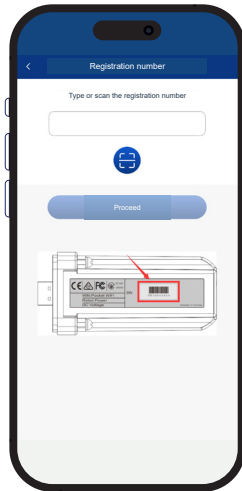

4. To create a new account enter the required data (Italy time zone UTC +01:00) and press "OK".

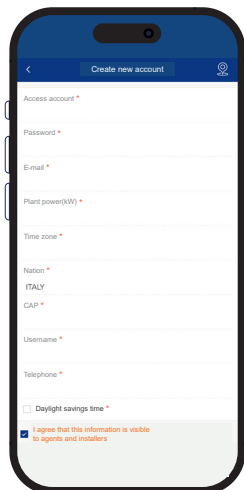

Connection procedure

1. Log in to the App with the credentials you just created.
2. Enter the User > Wi-Fi Connection section, type or scan the monitoring SN printed on the Wi-Fi module itself and press "Next".

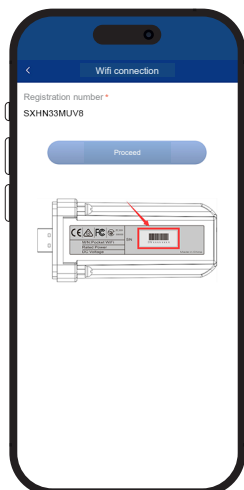

3. At the message "Peimar X portal wants to access the Wi-Fi network", press the option "Login".
4. Enter the name of the home wi-fi network (SSID) and relative password.



PLEASE NOTE

Network name and password must contain only numbers or letters, no special characters are accepted

- 5 If the entire procedure has been followed correctly, the module LED, where present, will become permanently on and after a few minutes the app will start receiving production data from the inverter and it will be possible to view them remotely.

13.3. Configuration via Ethernet cable (LAN) with PSI-XH-ETH-3.0

If the Wi-Fi signal is too weak, it is also possible to connect to the server through an Ethernet cable. You will have to purchase the PSI-X-H-ETH-3.0 module of the ethernet port, which allows the connection of the inverter via data cable to the router of the house (The PSI-X3P-TPM three-phase grid inverters already have the Ethernet module included) Install the PSI-X-ETH-3.0 module into the dongle port of the inverter. The installer will need to procure a category 5e or higher data cable on their own.

Insert the Ethernet module into its USB port on the bottom of the inverter (WIFI for inverters of the PSI-X3P-HY series, Upgrade/Dongle for inverters of the PSI-X1P-HY and PSI-X3S-HY series, DONGLE for PSI-X1P-TL/TLM series inverters and PSI-X3PTP/TPM);

The installer will need to procure a Category 5e or better data cable himself.

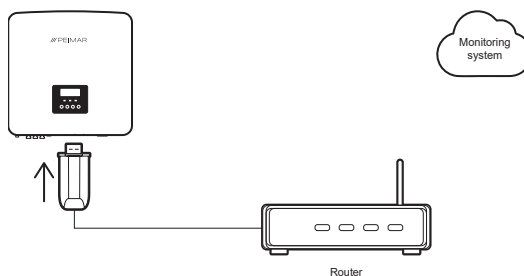

**PLEASE NOTE**

To complete the configuration of the monitoring system, the same procedure described in the paragraphs "Creating an end user account" must be followed for configuration via the Wi-Fi module from the browser or from the App;

the procedure described in the "Connection procedure" paragraph is not necessary as the connection is made directly via cable.

When prompted to enter the "monitoring SN", enter the code on the label of the ethernet module in place of the code on the label of the Wi-Fi module.

14. Error codes and troubleshooting

TYPE OF ERROR	RESOLUTION
GridVol_OVP1	Mains voltage overload: Check that the mains voltage is within the allowable range; Try restarting the inverter
GridVol_UVP1	Low voltage mains voltage : Check that the mains voltage is within the permissible range; Try restarting the inverter
GridFreq_OF1	Grid frequency highest value of the range: Check that the network frequency is within the allowable range; Try restarting the inverter
GridFreq_UF1	Grid frequency lowest value of the range: Check that the network frequency is within the allowable range; Try restarting the inverter
GridPhase_Loss	Grid phase voltage loss: Check the voltage of the network Check the AC switch of the mains electrical connection Try restarting the inverter
Grid_Unbalance	Grid voltage unbalance: Check if the mains voltage is within the allowed range; Try restarting the inverter
Grid_FRT	Network error: Check if the mains voltage is within the allowed range; Try restarting the inverter;
PV_Above_Bus	PV high voltage instantaneous Try restarting the inverter
PV_VolHigh	PV input overvoltage error: Check the PV voltage and confirm it is within the permitted range; Reduce the number of PV panels in series and reduce the PV voltage
DCBus_HW_OVP	Bus hardware PV overvoltage: Check the PV voltage and confirm it is within the allowable range; 2. Try restarting the inverter;
DCBus_SW_OVP	PV Overvoltage Bus Software: Check the PV voltage and confirm it is within the allowable range; Try restarting the inverter
PBus_FSW_OVP	Software bus overvoltage Try restarting the inverter

NBus_FSW_OVP	Software bus overvoltage Try restarting the inverter
DCBus_Unbalance	Bus PV Imbalance: Try restarting the inverter;
DcBus_SSErr	Bus soft start error Try restarting the inverter;
GridVol_OVP_10M	Mains voltage overload: Check that the mains voltage is within the allowable range; Try restarting the inverter
BST_SW_OCP	MPPT software overcurrent error: Check if the PV input is short circuited Try restarting the inverter
Iso_Fail	PV insulation below safe value: Check the insulation of the AC and DC line Check grounding
SunPWR_Weak	Low photovoltaic power Try restarting the inverter
InvRelay_Err	Relay fault Try restarting the inverter
Relay_OnErr	Relay activation error Try restarting the inverter
Inv_SW_OCP	Inverter software overcurrent Try restarting the inverter
Inv_PkCur_OL	Inverter software overcurrent Try restarting the inverter
Inv_DCI_Err	DC input above the allowed value Try restarting the inverter
Inv_SC_Err	Output Short Circuit Error Try restarting the inverter
Inv_HW_OCPA	Inverter hardware overcurrent error Try restarting the inverter
Inv_IGBT_NTC_OTP	The temperature of the inverter module is higher than the permissible value Check that the inverter is well ventilated. Try restarting the inverter
GFCL_CT_Err	GFCL sensor error Try restarting the inverter

Comm_SPI_Err	SPI communication error Try restarting the inverter
Comm_CAN_Err	CAN communication error Try restarting the inverter
EPRM_RW_Err	EPRM error Try restarting the inverter
MOV_AC_Err	Failure of the AC protection module Try restarting the inverter
MOV_DC_Err	DC protection module failure Try restarting the inverter
Type_Model_Err	Template settings error Try restarting the inverter
PV01_Reverse	Reverse connection of MPPT PV string: Verify that the electrical connection of the PV module is correct;
Meter_Opposite	Wrong Meter direction: Check the correct direction of the meter.
Remote_Off	The inverter receives the shutdown command and is in the stop state: Restart the inverter by sending a start command via the app or via the web.
Freq_Cfg_Err	Grid rated frequency setting error Check if the power grid status/power is set correctly.
Gnd_Conn_Err	Inverter ground connection error Check if the neutral is connected correctly Check if the earth wire is connection properly Try restarting the inverter
BST_HW_OCP	MPPT hardware overcurrent error: Check if the PV input is short circuited Try restarting the inverter
Bst_IGBT_NTC_OTP	Boost module temperature above the permissible value Check that the inverter is well ventilated Try restarting the inverter
Grid_Loss	Mains power failure / AC line or AC switch disconnection: Check if the mains voltage is normal; Check if the AC switch connecting electricity to the mains; Try restarting the inverter

GridVol_OVP_INST	Instantaneous grid power overload: Check the insulation of the AC and DC line Check grounding
AC_TB_NTC_OTP	The temperature of the AC terminal is higher than the allowable value Check that the AC terminal of the inverter is well wired Try restarting the inverter
Envir_Tmp_Low	The internal temperature exceeds the permissible value Check that the inverter is well ventilated Try restarting the inverter
Envir_Tmp_High	The internal temperature is higher than the permitted value Check that the AC terminal of the inverter is well soldered Try restarting the inverter
Envir_Tmp_OTP	The internal temperature exceeds the permissible value Check that the inverter is well ventilated Try restarting the inverter
SW_VerMisMatch	Software version error Try restarting the inverter
TmpSensor_Loss	Temperature sensor connection error Try restarting the inverter
Fan1 Warning	Abnormal operation of fan 1: Check that the fan is working properly
Fan2 Warning	Abnormal operation of fan 2: Check that the fan is working properly

15. Periodic maintenance

In most cases, inverters do not need any maintenance or repairs, but if the inverter often loses power due to overheating, the problem may be due to the following reasons:

- The heat sink on the back of the inverter is dirty. If necessary, clean it with a soft, dry cloth or brush. Only trained and authorized professional personnel who are familiar with the safety requirements may carry out maintenance.
- That the input and output cables are in good condition and not damaged (do this check at least every 6 months).

16. Disposal



This device MUST NOT be disposed off as municipal waste.

The crossed-out wheeled bin symbol on the device label indicates that the product at the end of its useful life must be collected separately from other waste to allow for proper treatment and recycling. The user will therefore have to deliver the equipment that has reached the end of its life free of charge to the appropriate municipal centers for the separate collection of electrical and electronic waste, or return it to the dealer according to the 1 against 1 method when purchasing a new equivalent product. Adequate separate collection for the subsequent sending of the decommissioned equipment to environmentally compatible recycling, treatment and disposal helps to avoid possible negative effects on the environment and health, and promotes the re-use and/or recycling of the materials it is made of the equipment. Illegal disposal of the product by the user involves the application of the sanctions referred to in current legislation.

17. Warranty conditions

For the warranty conditions, refer to the relative document which can be downloaded from the website www.peimar.com.

/// PEIMAR



info@peimar.com | www.peimar.com