

PSI-X3P6000-TP
PSI-X3P8000-TP
PSI-X3P10000-TP

EN

THREE-PHASE ONGRID INVERTER

User Manual

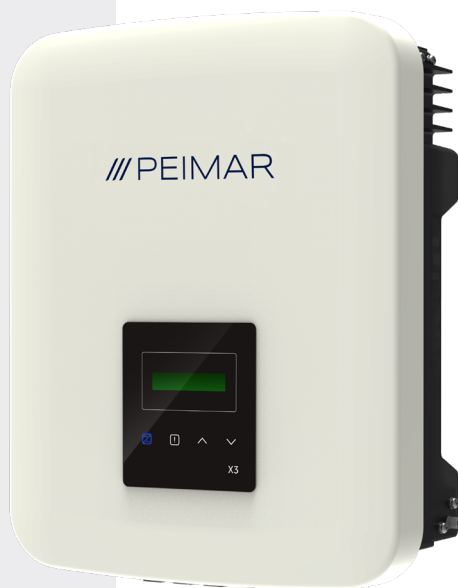

/// PEIMAR

It should be noted that the technical data, information and representations contained in this document have a purely indicative value. Peimar reserves the right to modify the data, drawings and information contained in this document at any time and without notice.

/// PEIMAR

Introduction	6
1. Security measures	6
1.1. Security tips	6
1.2. Legend of safety symbols	6
1.3. Safety instructions	7
1.4. Key to symbols on the label	10
2. Product information	12
2.1. Field of application	12
2.2. Product model specifications	12
2.3. Overall dimensions of the products	12
2.4. List of components	13
3. Instruction for installation	14
3.1. Packing check	14
3.2. Place of installation	14
3.3. Methods of installation and placement	14
3.4. Assembly procedure	16
4. Installation hypothesis	18
4.1. Configuration of PSI-X3P-TP three-phase grid inverter	18
5. Electrical connection	20
5.1. Connection inputs for the inverter	20
5.2. PV connection	20
5.3. AC Connection	25
5.4. Connection of communication ports.....	28
5.4.1. Meter PSI-X-3PMETER-HY	28

6. Earth connection	33
7. Parallel conn. of multiple PSI-X3P-TP series inverters	34
8. Starting the inverter	35
9. Setting and display interface	36
10. Block diagram of the inverter screens	37
11. Main functions on display	38
12. Firmware Version	42
13. Configuring the PSI-X Inverter Monitoring System	43
13.1. Installer account creation	43
13.2. Configuration via Wi-Fi module	43
13.2.1. Configuration via browser Wi-Fi module	44
13.2.2. Configuration via Wi-Fi module from app	47
13.3. Config. via Ethernet cable (LAN) with PSI-X-H-ETH-3.0	50
14. Error codes and troubleshooting	51
15. Periodic maintenance	54
16. Disposal	54
17. Warranty conditions	54

Introduction

This user manual defines detailed instructions and procedures for the installation, operation, maintenance and troubleshooting of the following grid connected Peimar inverters:

PSI-X3P6000-TP	PSI-X3P8000-TP	PSI-X3P10000-TP
-----------------------	-----------------------	------------------------

Please always keep this manual where it is accessible all the time.

1. Security measures

1.1. Security tips

The inverter is a device directly connected to a HIGH VOLTAGE electric generator; The installation, maintenance and repair of the inverter can only be carried out by qualified personnel, who have carefully read and fully understood all the safety regulations contained in this manual. Keep the user manual properly.

1.2. Legend of safety symbols



DANGER

Indicates a hazardous situation which, if not avoided, will result in death or serious injury.



WARNING

Indicates a hazardous situation which, if not avoided, could result in death, serious injury, or moderate injury.



ATTENTION

Indicates a hazardous condition which, if not avoided, could result in minor or moderate injury.



NOTICE

Indicates a situation that could lead to potential damage if not avoided.

1.3. Safety instructions



DANGER

1. The user must comply with the applicable electrical codes, national and local regulations during the installation, operation and maintenance of the inverter, to avoid incurring personal injury or death, and damage to the inverter.
2. The work must be performed by qualified personnel and the equipment must be handled by persons with adequate experience and knowledge.
3. Do not touch the parts of the inverter while the device is running; There is danger to death from electric shock and high voltage.
4. To prevent the risk of an electric shock during installation and maintenance, please make sure that all AC and DC terminals are disconnected from the inverter, and never touch the positive and negative pole of the PV connection device simultaneously.
5. Make sure that the existing wiring is in good condition and that the cables are not undersized. The wiring must be carried out in a way so that the length of the cables is as short as possible.
6. Do not touch the inverter surface while the coating is wet; could cause an electric shock.
7. Do not stay close to the inverter during bad weather conditions including storm, lightning, etc.
8. Before touching the coating, the Peimar inverter must be disconnected from the grid and from the photovoltaic generator; it is necessary to wait at least five minutes to allow the energy storage capacitors to fully discharge after being disconnected from the energy source. Measure the voltage between the positive and negative poles of the PV connecting device to ensure that the device is discharged before carrying out any work on the inverter.
9. The island effect is a particular phenomenon where the photovoltaic system continues to feed energy into the grid even when there is a grid loss in the electricity system; this is a dangerous phenomenon for maintenance personnel and the public. The inverters of this series are equipped with an integrated protection to avoid the islanding effect.

10. The inverters of this series are equipped with a certified internal residual current device to protect against possible electric shock and fire hazards in the event of a malfunction of the PV array, cables or inverter. If the local regulations require an external differential, install a magneto-thermal differential switch downstream of the AC side output, with a differential of at least type A (a type A or F differential is recommended) and a tripping threshold $I_{dn}=0.3A$.



WARNING

- 1 The installation, maintenance, recycling and disposal of the inverters must be carried out only by qualified personnel, in compliance with the national and local laws and regulations in force with the use of suitable equipment. Prevent the inverter from being used by children or unqualified personnel.
2. The installation site must be away from moisture and corrosive agents.
3. Any unauthorized action, including the modification of any type of product functionality, may result in damage to the components and a lethal danger to the operator, or to third parties.
4. Do not disassemble the parts of the inverter that are not mentioned in the installation guide. In the event of improper modifications Peimar is not responsible for any damage and abstains from any liability relating to the guarantee of the mentioned product.
5. The Peimar inverter must only be used in combination with photovoltaic panels, in compliance with current regulations; do not connect other energy sources to the Peimar inverter.
6. Use only the recommended accessories. Otherwise, you run the risk of fire, electric shock, or injury.
7. Make sure that the photovoltaic generator and the inverter are correctly connected to the earth system; Improper grounding can cause personal injury, death, or equipment malfunction and increase electromagnetic emissions. Make sure that the ground conductor is adequately sized as required by safety standards. Do not connect the earth terminals of the unit in series in case of multiple installation.
8. Keep away from flammable and explosive materials to avoid fire.
9. Never touch the positive and negative poles of the PV part together and never touch each other at the same time.

10. The unit contains capacitors which remain charged even after the electrical power has been removed; wait at least 5 minutes after disconnection. Make sure there is no voltage before operating.



ATTENTION

1. The photovoltaic inverter can reach high temperatures during operation. Please do not touch the heat sink or side surface during operation or immediately after turning the power off to avoid the risk of burns.
2. To prevent damage and personal injury, hold the inverter firmly when moving it, as it is a heavy piece of equipment.
3. Staying at a distance of less than 20 cm from the inverter for a long time could cause damage to health due to radiation.



NOTICE

1. The photovoltaic inverter is designed to feed alternating current energy directly into the public electricity grid; do not connect the AC output of the inverter to any device that is not connected to the electricity grid.
2. There can be damage to the photovoltaic system both due to direct lightning strikes and overvoltage due to nearby discharges. Induced overvoltage is the most likely cause of damage especially in rural areas, where electricity is usually supplied by long power lines. Overvoltage can be induced both on DC cables and on AC cables leading into the building. The project planner, based on the lightning risk and what is required by current legislation, will evaluate the need to install any additional external surge arresters with respect to the SPDs already supplied with the inverter, for the protection of the PV side and AC side circuits.

1.4. Key to symbols on the label



DANGEROUS ELECTRIC VOLTAGE

This device is directly connected to the public electricity grid, therefore any work on the inverter must be carried out by qualified personnel.



DANGER TO LIFE due to high voltage

There may be residual voltage in the inverter due to the high capacity of the condenser. Wait 5 MINUTES after disconnecting the appliance before touching the coating or carrying out maintenance on the system.



WARNING, DANGER!

The appliance is directly connected to electric generators and to the public electricity grid.



DANGER HOT PARTS

The elements inside the inverter reach high temperatures during operation. Do not touch the metal case when the inverter is active (risk of burns).



This device MUST NOT be disposed off as municipal waste

Please refer to the "Disposal" chapter of this manual for proper management of the disposal of the inverter.

**WITHOUT TRANSFORMER**

This inverter does not have an isolation transformer.

**EARTHING**

The connection point of the protective conductor for earthing is indicated on the inverter.

**CE MARK**

Devices with the CE mark meet the essential requirements of the Low Voltage Directive and the Electromagnetic Compatibility Directive.

RoHS RoHS

This device complies with the directive ROHS (Restriction of Hazardous Substances)

**INSTRUCTIONS**

Refer to the present manual for inverter installation, operation, maintenance, and troubleshooting instructions.

2. Product information

2.1. Field of application

The inverters in this manual are three-phase grid inverters, which receive electricity generated in direct current (DC) by photovoltaic panels and convert it into alternating current (AC), in accordance with the requirements of the public grid.

2.2. Product model specifications

PSI-X3PXXXX-TP

- PSI-X3P indicates the series name of the inverter
- XXXX indicates the nominal power in W of the inverter
- TP indicates that it is a three-phase transformerless inverter with MPPT single DC input

2.3. Overall dimensions of the products

The inverters in this manual have the dimensions shown in the figure below:

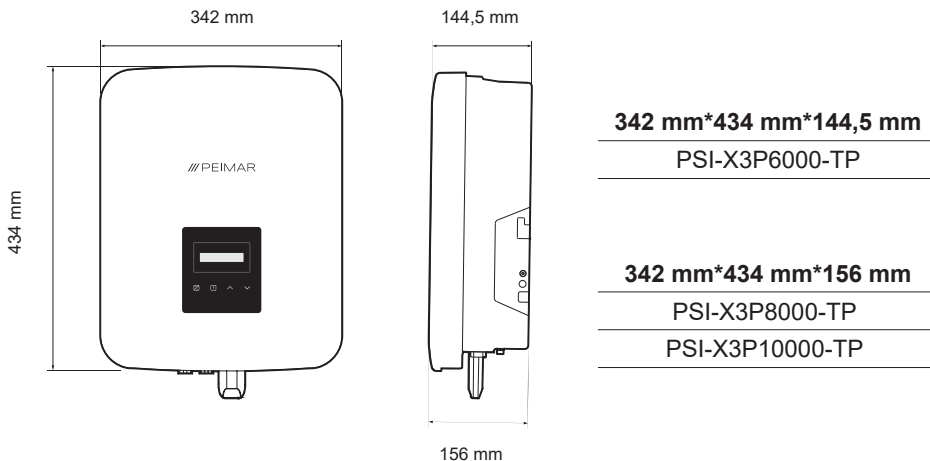

2.4. List of components

Specifications	Quantity
Inverter	1
Support bracket already screwed to the inverter	1
Positive DC connectors	2
Negative DC connectors	2
Positive DC pin connectors	2
Negative DC pin connectors	2
Screw anchors	3
Screw washers	3
Expansion screws	3
Ring terminal for grounding	1
Waterproof connector with RJ45 plug	1
AC connector	1
TCEI M5 bolt for fixing the support bracket	1
AC connector	1
TCEI M5 screw for fixing the support bracket	1
AC line waterproof cover	1
Installation manual	1
PSI-X-H-WIFI-3.0	1
MC4 connectors assembly-disassembly tool	1



Content control

Please refer to the list of accessory components contained in the package and check that they are all present before proceeding with the installation; if there are any missing components, contact your dealer as soon as possible.

Please keep the original packaging in case you need to return the product for repair or replacement.

3. Instruction for installation

3.1. Packing check

Although Peimar inverters have passed rigorous checks and are tested before they leave the factory, it is not excluded that they may suffer damage during transport. Please check that the packaging has not shown any obvious signs of damage; in the event that such evidence occurs, please do not open the box and contact your dealer as soon as possible.

3.2. Place of installation

This device is compatible with environmental pollution degree II for outdoor environment.

- The inverter has an IP66 degree of protection, so it can also be installed outdoors, but with the appropriate precautions: an inappropriate or non-compliant installation environment can compromise the life of the inverter.
- Do not expose the inverter to direct sunlight as this may cause power derating due to overheating
- It is not recommended to install the inverter with direct exposure to rain, excessive humidity or other bad weather
- The installation site must be well ventilated.
- The installation site must be away from corrosive, flammable or explosive substances.
- The place of installation must be far from antennas or electrical devices for the transmission and/or reception of electromagnetic waves
- The installation site must be at an altitude of less than 4000 m
- The ambient temperature should be between -30°C and +60°C.

3.3. Methods of installation and placement

Make sure that the inverter installation wall has sufficient strength to support the weight.

Do not place the inverter with the input/output terminals in contact with other surfaces, as these are not designed to support the weight of the inverter. Always place the inverter horizontally during the installation phases.

1. Please install the device as shown in the figure below. Vertical installation is recommended, or with a maximum inclination of $\pm 5^\circ$. Never install the inverter tilted sideways, horizontally or upside down. Install the inverter away from direct sunlight and avoid any accumulation of snow.

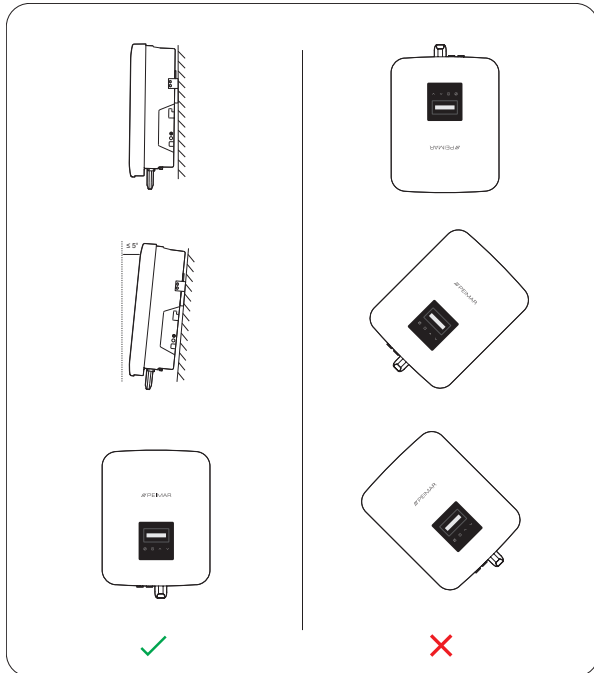

2. Install the inverter at eye level to facilitate viewing of the display and the possible maintenance activities.
3. Carry out the installation of the inverter providing for the possibility of disassembly for any maintenance works. Also make sure there is free space around the device to ensure ventilation, as shown in the figure below (see next page):

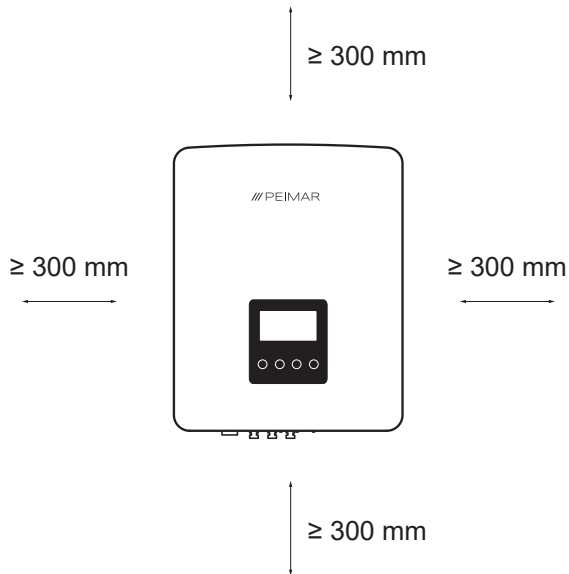

3.4. Assembly procedure

To proceed with the installation, provide yourself with all the tools such as: crimping pliers, screwdrivers, drill, Allen keys, etc.

1. Mark the position of the drilling points for mounting the anchor bracket on the wall using the holes on the template of the bracket;

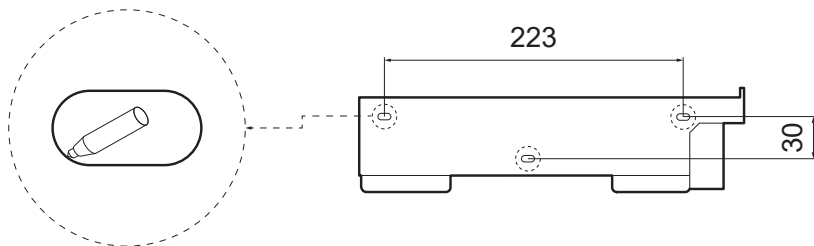

2. Drill the necessary holes in the wall ($\Phi 10$ and at least 60 mm deep) at the marked points and insert the wall plugs using a rubber hammer;

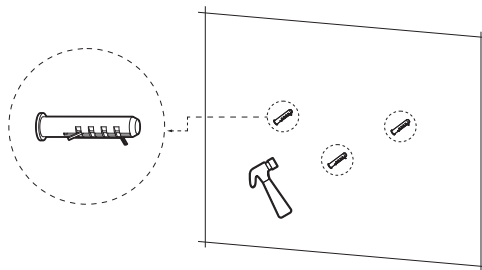

3. Fix the anchor bracket to the wall, screwing the screws into the plugs;

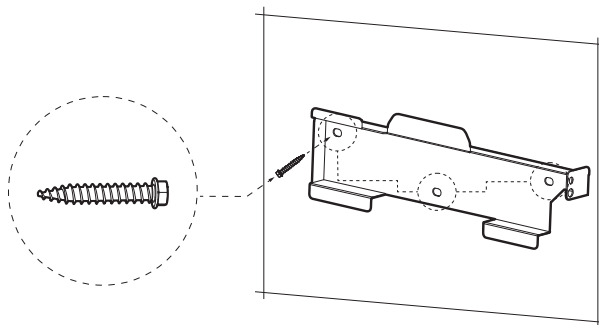

4. Carefully fix the inverter to the bracket, making sure that the rear of the device is mounted snugly against the bracket. Then place the inverter on the bracket and tighten the screws to ensure correct fixing.

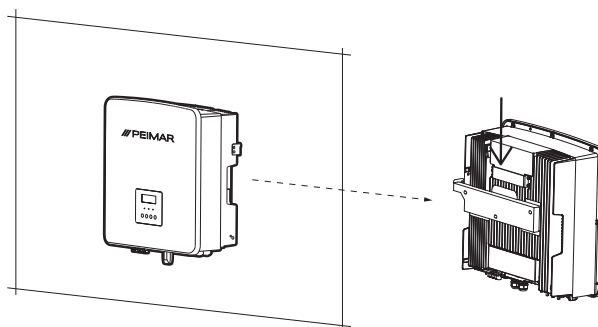

4. Installation hypothesis

4.1. Configuration of PSI-X3P-TP three-phase grid inverter

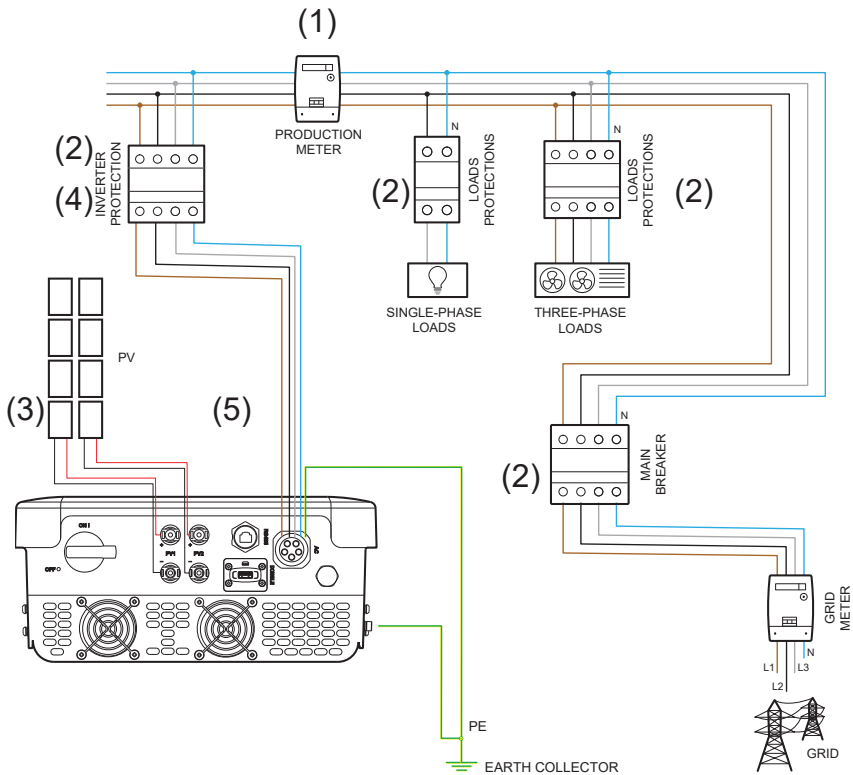

1. The position of the energy meter indicated in the diagram is purely indicative and to be evaluated in agreement with the project planner on the basis of the regulations in force at the time of installation and of any other existing systems.
2. The protections indicated on the diagram and their position are purely indicative and to be evaluated in agreement with the project planner on the basis of the regulations in force at the time of installation and of any other existing systems.



PLEASE NOTE

Peimar does not provide the protections described in this document. Contact your distributor to purchase.

3. For correct operation of the inverter, ensure that voltage and current compatibility between the inverter and photovoltaic strings is respected. The inverters are equipped with two DC inputs connected in parallel for each MPPT. It is not necessary to connect both strings, but if the configuration chosen for the system requires it, they must be the same. We recommend using all MPPTs of the inverter. For further details, consult the chapter on PV connections in this manual.
4. For safety and in compliance with regulations, provide for the installation of a circuit breaker downstream of the AC side output, with at least a type A differential and an intervention threshold $I_{dn}=0.3\text{ A}$. Size the AC line accordingly based on the distance between the inverter and the exchange meter. For further details, see the chapter on AC connections in this manual.
5. The project planner will evaluate the need to install any additional external arresters or not, compared to the overvoltage protections (SPD) already supplied with the inverter, for the protection of the photovoltaic side and AC side circuits. For further details, consult the chapter on PV and AC connections in this manual.

5. Electrical connection

5.1. Connection inputs for the inverter

The inputs on the underside of the inverter are shown below

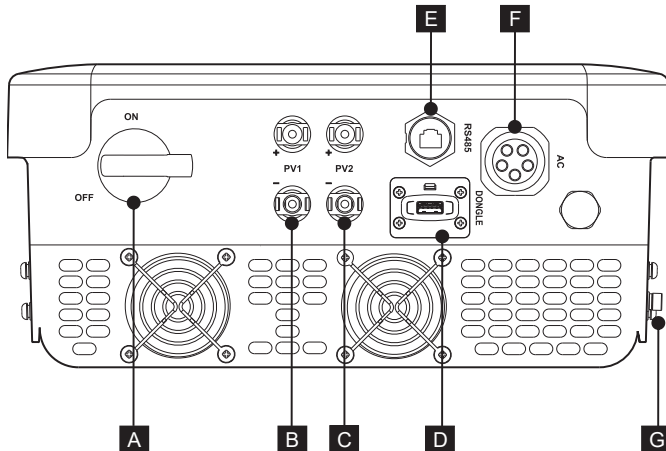

A	DC switch
B	Photovoltaic inputs (PV1)
C	Photovoltaic inputs (PV2)
D	USB port for Wi-Fi/Ethernet module connection
E	RS485 port
F	AC connection input
G	Ground connection hole

5.2. PV connection

Before proceeding with the connections, it is advisable to pay attention to the following technical requirements:

- It is important to connect only modules with the same electrical characteristics (same model of the panel) and same orientation and exposure to the sun on the same string.

- If there are panels with different electrical characteristics (different models; different number of modules in series; different orientation; etc.) it is necessary to use independent MPPTs which act separately.

For correct operation of the inverter, make sure that the voltage and current compatibility between the inverter and the photovoltaic strings are respected.



NOTICE

Make sure that the voltage and current of the strings do not exceed those at the inverter input; an incorrect configuration can cause permanent damage to the inverter, which will not be included in the warranty, make sure that:

V_{oc_Tmin} (Open circuit voltage at minimum temperature) < V_{max_cc} (maximum DC voltage)

V_{mp_Tmin} (Voltage at Pmax at minimum temperature) < V_{max_mppt} (MPPT maximum voltage)

V_{mp_Tmin} (Voltage at Pmax at minimum temperature) < V_{max_sis} (maximum panel system voltage)

I_{mp_Tmax} (Current at Pmax at maximum temperature) < I_{max_mppt} (maximum MPPT current)



NOTICE

Make sure that the string voltage is higher than the inverter start-up voltage or the system may not turn on or have poor efficiency:

V_{oc_Tmax} (Open circuit voltage at maximum temperature) > V_{start} (startup voltage)

V_{mp_Tmax} (Voltage at Pmax at maximum temperature) > V_{min_mppt} (minimum voltage of the MPPT)

The positive and negative PV inputs are located on the underside of the inverter. It is recommended to use all the MPPTs (PV1, PV2 and PV3 if present) to make the most of the inverter.

1. It is possible for each MPPT to connect only one string, it is not necessary to use both DC inputs.

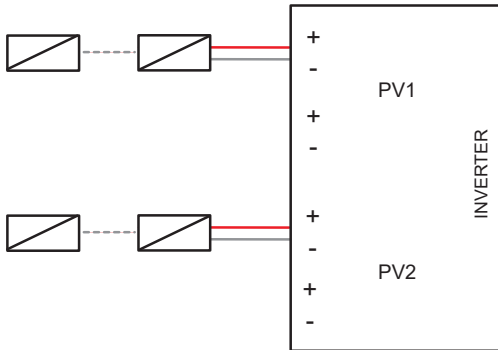

- The maximum current on each output is 16 A. In the case of a string with a current greater than 16 A, it is necessary to use Y connectors to be connected to both MPPTs (PV1 and PV2), in order to have a maximum input current of 32A.

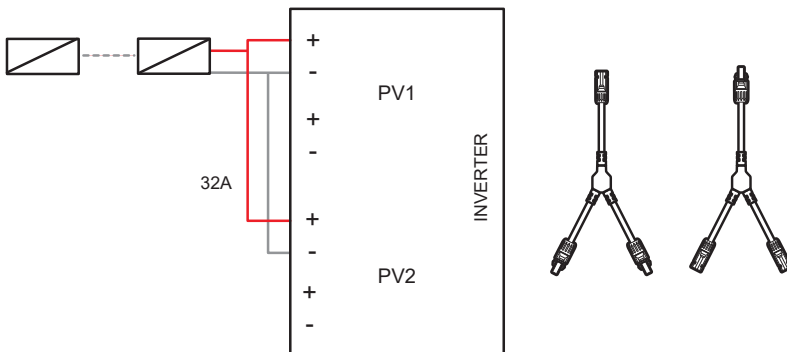

PLEASE NOTE

If a photovoltaic configuration with strings in parallel is required, the parallel MPPT function must be set using the following procedure:

MENU > OPTIONS (PASSWORD 2014) > PV CONNECTION > MULTI/COMM

The multi option is to be selected if the MPPTs are used independently (SCHEMES 1) the comm option is to be selected if the MPPTs are put in parallel with each other (SCHEME 2).

The inverter has built-in overvoltage protection; The project planner, on the basis of the risk of lightning and what is required by current legislation, will evaluate the need to install any additional external unloaders with respect to the SPDs already supplied with the inverter, for the protection of the photovoltaic side circuits.

To connect a photovoltaic string to the inverter, two solar cables are required which are in turn connected to the positive and negative DC inputs of the inverter. The cables on the inverter side, are to be used by the connectors provided in the package. The cables on the side of the panels, obtain the appropriate MC4 or compatible connectors. (see diagram below)

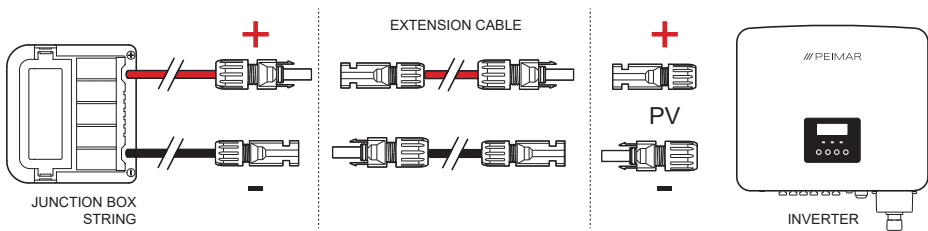

PLEASE NOTE

Peimar does not supply the solar cables and MC4 connectors from the side of the panels described above in this document. Contact your distributor to purchase.

DC connection procedure

For the DC connection, observe the following assembly procedure:

1. Before connecting the photovoltaic strings to the inverter, make sure that the DC switch of the inverter is turned to OFF; Take the positive and negative MC4 connectors from the package, including the waterproof gasket, locking ring nut and metal pin, which will be mounted on the string terminals to make the connection with the inverter.
2. Strip the ends of the cables connected to the photovoltaic string by about 7 mm and crimp the metal pin of the MC4 connectors with pliers, taking care to respect the polarities and tighten the pin contact well. The recommended section of the photovoltaic cable is 4mm.

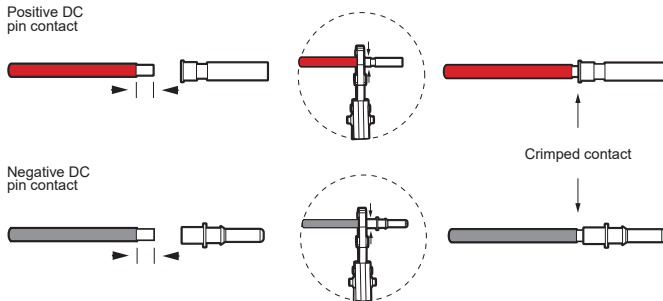

3. Insert the locking ring and the waterproof gasket of each MC4 connector on the PV string cables. Pair the plugs to the respective metal pins, paying attention to respect the polarities; you will hear a "click" indicating that the connection is complete.

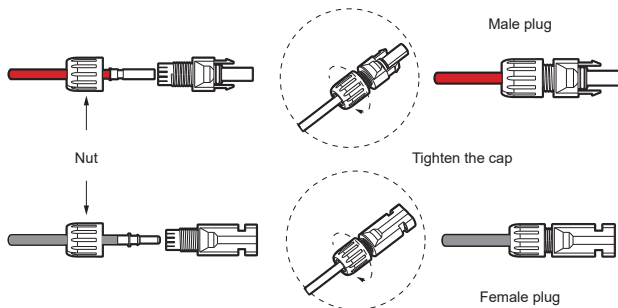

4. Finally screw the locking collar onto the head of the plug. Connect the positive and negative connectors into the respective DC input terminals of the inverter; you should hear a click when the connectors are properly connected.

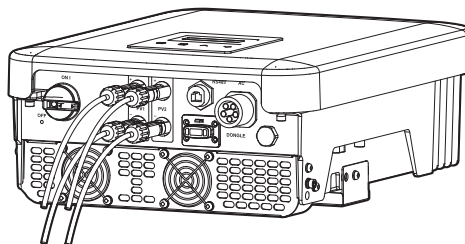

**PLEASE NOTE**

It is advisable to use a suitable tool during the assembly and disassembly operations of the MC4 connectors to avoid the risk of damaging them.

5.3. AC Connection

The inverters of the series described here are intended for three-phase connection. For connection to the alternating line, follow the instructions of the local public network.

For safety and in compliance with the regulations, provide for the installation of a magneto-thermal differential switch downstream of the AC side output, with a differential of at least type A (a type A or F differential is recommended) and an I_{dn} tripping threshold =0.3A.

**PLEASE NOTE**

Direct connection of any loads is not recommended, without the presence of adequate protections.

Size the AC line according to the distance between the inverter and the exchange meter. For limits and recommended values, refer to the table below:

	Nominal Power (kW)	Recommended switch size (A)	Cable section L1, L2, L3 (mm ²)	Cable section PE + N (mm ²)
PSI-X3P6000-TP	6	20 A	5-6	2,5-6
PSI-X3P8000-TP	8	32 A	5-6	2,5-6
PSI-X3P10000-TP	10	32 A	5-6	2,5-6

**NOTICE**

If the connection distance between the inverter and the grid is very large, please increase the AC cable cross-section, to avoid excessive voltage drop.

The inverter has built-in overvoltage protection; The project planner, on the basis of the risk of lightning and what is required by current legislation, will evaluate the need to install any additional external arresters with respect to the protections already supplied with the inverter, for the protection of the alternating current side circuits.

Check that the voltage arriving from the grid is compatible with the voltage supported by the inverter.

AC connection procedure

For the AC connection observe the following assembly procedure:

1. Check the connection type according to your local grid and make sure you have cut off the AC side power supply;
2. Arrange the AC line cables of the appropriate size, strip the ends of about 12 mm; then take the AC line waterproof connector from the package;
3. Prepare the connector by unscrewing and separating it into three parts: male insert, rear shell and ferrule with rubber insert; then insert the cable inside the parts as shown in the photo;

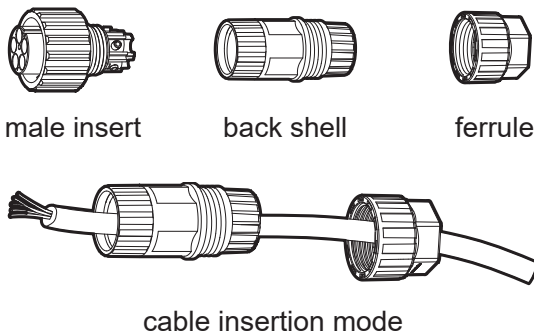

4. Insert the stripped leads of the AC cable into the appropriate holes of the Male Insert. The N cable and the PE earth must be placed correctly. Then insert the 3 phases and tighten them with a hex key;

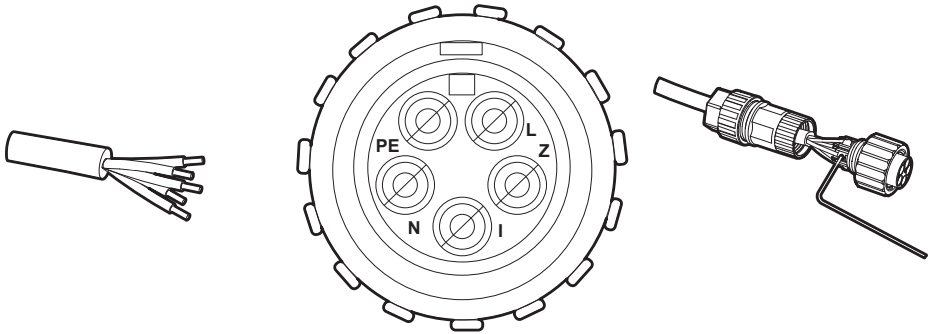

PLEASE NOTE

The phases can also be connected in different order.

5. Screw respectively the rear shell on the bit head and finally also the nut with rubber insert.

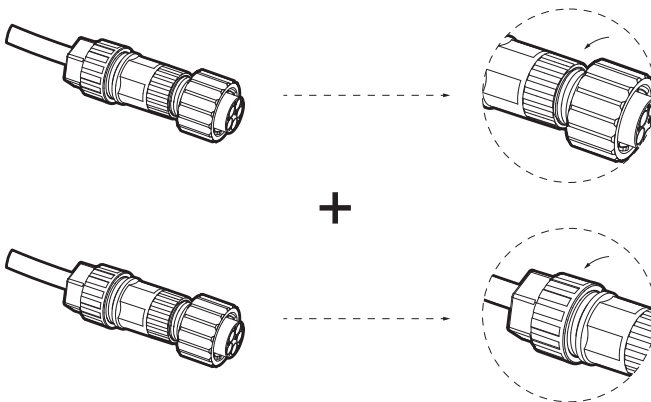

6. Screw the newly assembled male insert into the female terminal on the inverter.

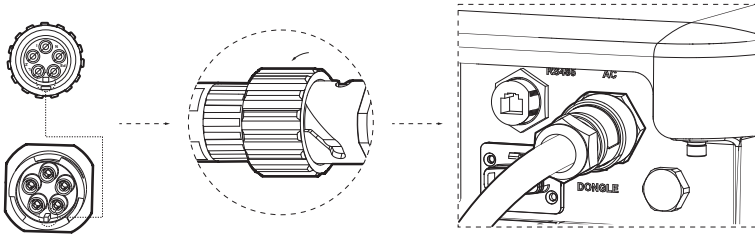

PLEASE NOTE

It is not possible to connect to the AC line without using the neutral wire.

5.4. Connection of communication ports

In the lower part of the inverter there is an RS485 port, thanks to which the inverter can:

- Communicate with the PC, data hub or other devices, the meter and activate the parallel function;
- Activate multiple functions such as DRM, the "Dry Contact" function and control a heat pump via the Adapter Box.

5.4.1. Meter PSI-X-3PMETER-HY

The meter is a device that allows you to analyze the energy flow of the system to manage it appropriately; the meter compatible with the three-phase inverters described here for currents up to 80 A is the PSI-X-3PMETER-HY with direct connection.

The meter also allows you to set the "Export Control" function which defines the power transferred to the grid. By default, the energy produced that is not self-consumed by the plant will be fed into the grid; if the user does not want to transfer power to the grid, he will have to set the value "0 Watt" in the advanced options of the inverter.

The Meter must be installed upstream of all network loads, downstream of the exchange meter; refer to the diagram below (the position of the energy meter produced and of the protections indicated in the diagram are purely indicative and to be evaluated in agreement with the project planner based on the regulations in force at the time of installation and of any other existing systems:

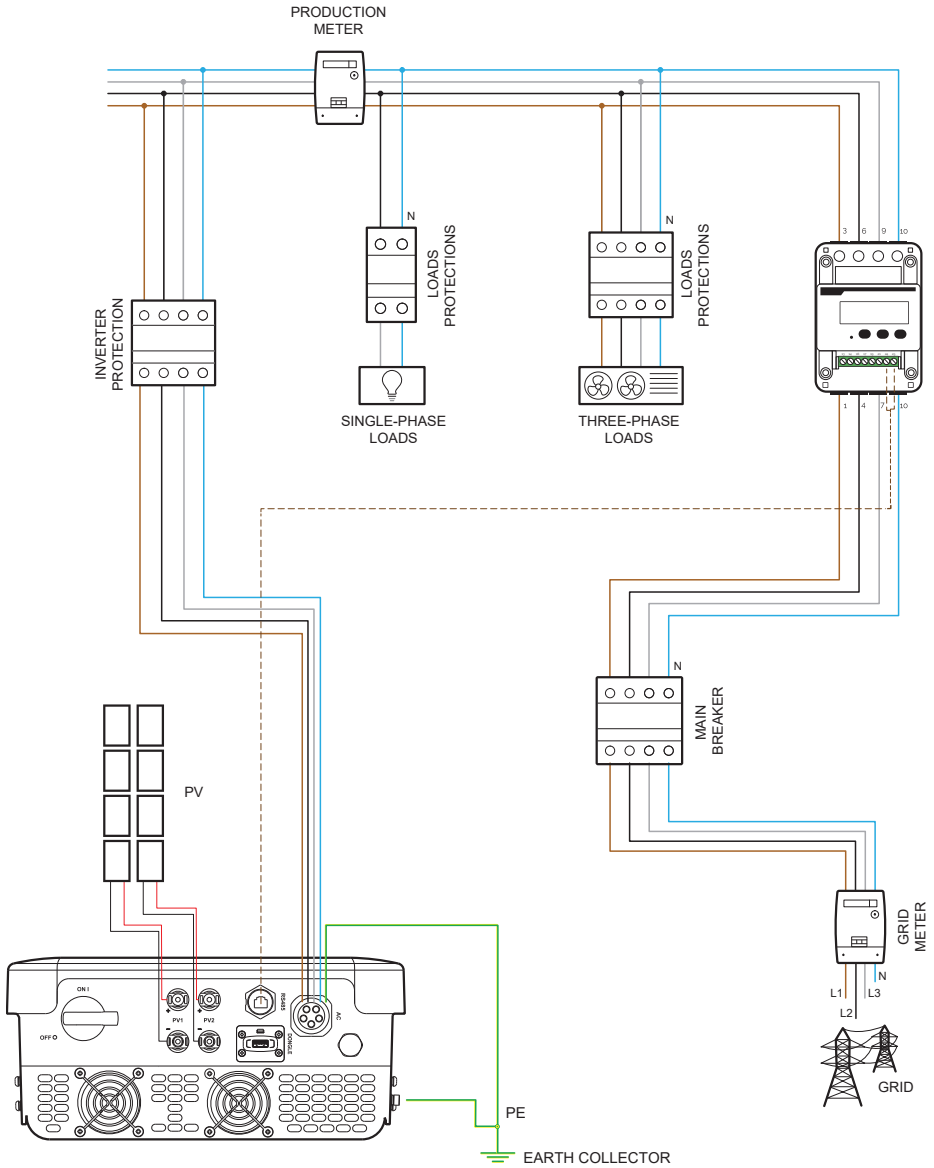

For the connection of the PSI-X-3PMETER-HY meter observe the following assembly procedure:



NOTICE

Make sure you have cut off the AC side power on the utility line.

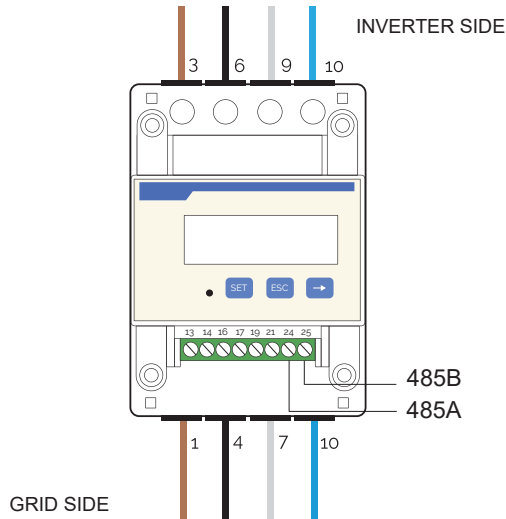

1. Strip the three phases arriving from the exchange meter (mains side) by 8-10 mm and secure them respectively to inputs 1, 4 and 7 of the meter by tightening the terminal.
2. Strip the three phases arriving from the system (inverter side) by 8-10mm and fix them respectively to outputs 3, 6 and 9 of the meter by tightening the terminal.
3. Strip the neutral cables arriving from the exchange meter (grid side) and from the system (inverter side) by 8-10 mm and secure them to input 10 both at the input and at the output.
4. Lay a twisted-pair cable long enough to span the distance between the inverter and the meter (a 10m cable is included in the package). Insert the two wires of a terminal into outputs 24 and 25 of the meter and fix them by tightening the clamp.

5. For the connection on the inverter side, refer to the paragraph below
6. Once the electrical connection phase has been completed, fix the PSI-X-3PMETER-HY meter on 35 mm guides. Since the meter is neither waterproof nor dustproof, it is recommended to install it inside the electrical panel.
7. The display of the PSI-X-3PMETER-HY meter lights up when voltage is supplied to the system.
8. The meter is already automatically set with the correct network parameters; by briefly pressing the "arrow" key it is possible to scroll and check the various set parameters.

Connection to the inverter

1. Crimp the two wires of the other end of the cable to an RJ45 plug so that there is continuity between:
 - Terminal 24 of the meter and Pin 4 of the plug
 - Terminal 25 of the meter and Pin 5 of the plug

If an RS485 communication cable is used, connect the blue wire to terminal 24 and the white/blue wire to terminal 25 of the meter; from the inverter side, crimp the blue wire to Pin 4 of the plug and the white-blue wire to Pin 5 of the plug.

Refer to the diagram below:

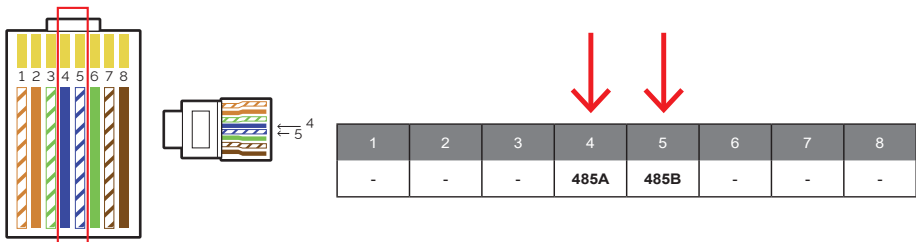

2. Connect the RJ45 plug to the RS485 port of the inverter.

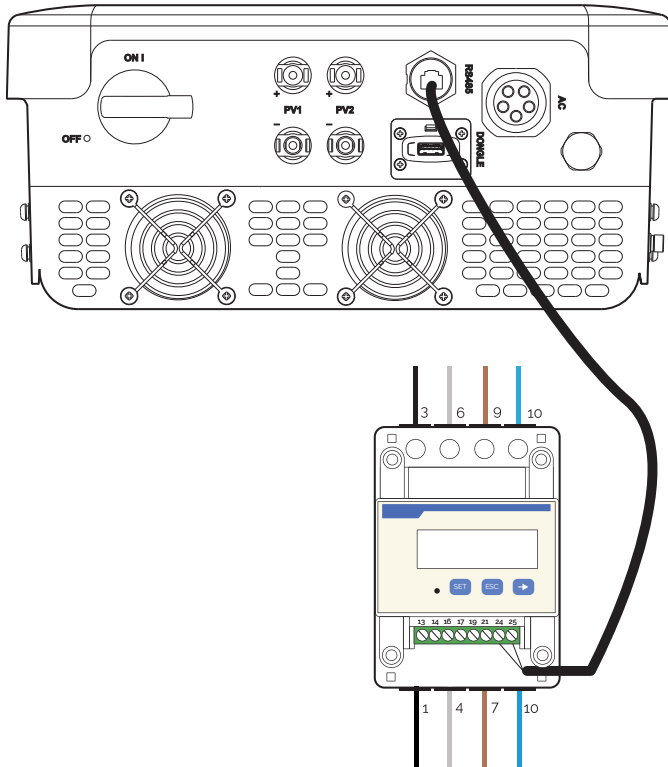

3. To activate the export limit function, activate the appropriate option in the advanced settings of the inverter;

From the display go to the menu:

MENU > OPTIONS > Password "2014" > EXPORT CONTROL > MODE > Meter > 0W

By default, the set value is 30000 W, it is possible to change it by entering a value between 0 and 30kW.



6. Earth connection

For the safety of the system, it is mandatory to earth the inverter:

- Crimp the earth wire terminal included in the box to the appropriate line.
- Secure the earth cable in the special hole on the inverter, identified by the earth symbol, by tightening the hexagonal head screw already screwed into the dissipator.

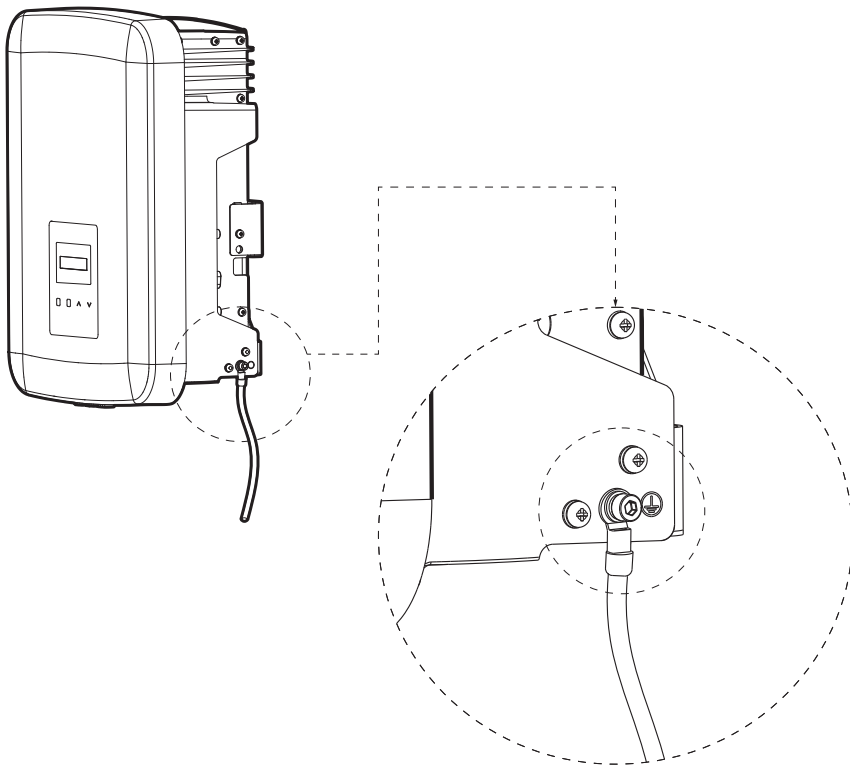

Torque: 1.2 ± 0.1 N*m

7. Parallel connection of multiple PSI-X3P-TP series inverters

This chapter describes the parallel connection of several inverters of the PSI-X3P-TP series, respectively with an output of 6 kW, 8 kW and 10 kW.

If it is not necessary to reduce the power fed into the grid or to read self-consumption, it is also possible to connect a greater number of inverters to the same three-phase line, without using the meter for energy management; it is however necessary to evaluate its feasibility with the system designer in compliance with current regulations.

If you want to connect several inverters in parallel, keeping the Meter to control the input/output of energy into the grid, an external device must be used.

The external device is also necessary if you want to make the parallel connection between inverters of the PSI-X3P-TP series with a power of 6 kW, 8 kW and 10 kW respectively and other models of the PSI-X3P series.



PLEASE NOTE

To be able to make this connection, please contact the manufacturer, in order to have specific technical information.

For systems with a rated power greater than 11.08 kW, the installation of an external interface protection system must be provided, as required by the regulations.

8. Starting the inverter

Before turning on the inverter, pay attention to the following:

1. Make sure the inverter is properly fixed to the wall;
2. Make sure the DC and AC switches on the inverter are in the "OFF" position;
3. Make sure the AC cord is properly connected to the network;
4. Verify that the DC and AC lines are properly connected;
5. Check that all photovoltaic panels are connected to the inverter correctly and that unused DC connectors are covered by the appropriate cover;



WARNING

Before starting the inverter, make sure you have completed all the electrical connections correctly

Inverter power-up procedure:

1. Be sure to turn on the DC and AC external protectors;
2. Turn the inverter DC line disconnect switch to On
3. The inverter turns on automatically when the PV panels generate enough energy;
4. Verify that the status of the LEDs is Blue and that the LCD screen is in the main screen;
5. If the LED is not Blue, check:
 - that all connections are correct;
 - that all external protections are closed;
 - that the DC switch of the inverter is set to "ON";

The correct start of the inverter is indicated in 3 different states:

Standby: the inverter checks that the DC voltage is between a minimum of 120 V (lowest voltage value for the start phase) and a maximum of 150 V (lowest voltage to be able to operate)

Control: the inverter will automatically control the DC input when the incoming voltage from the panels exceeds 150V;

Normal: the inverter starts working when the Blue light is on, and at the same time it transfers energy to the grid, showing its output power on the screen;

9. Setting and display interface

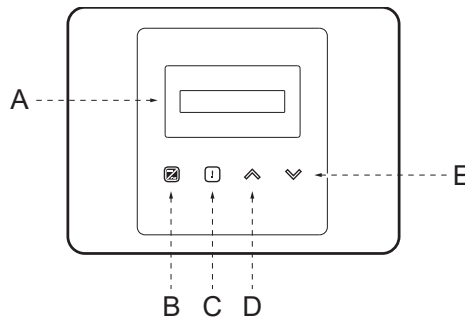

	Display	The display allows the inverter production data to be viewed and the operating parameters to be set
B	LED INDICATORS	Solid blue light: The inverter is in normal state Flashing blue light: The inverter is in waiting or checking state
C		Red light on: the inverter is in error state Off: The inverter has no error
D	FUNCTION BUTTON	UP/ESC key: if pressed quickly, scroll Up/Left or increase the selected value If pressed for a long time, it works as an ESC button and allows you to exit the current interface or function
E		DOWN/ENTER key: if pressed quickly, scroll Down/Right or decrease the selected value. If pressed and held, it functions as an ENTER button and confirms the selection

10. Block diagram of the inverter screens

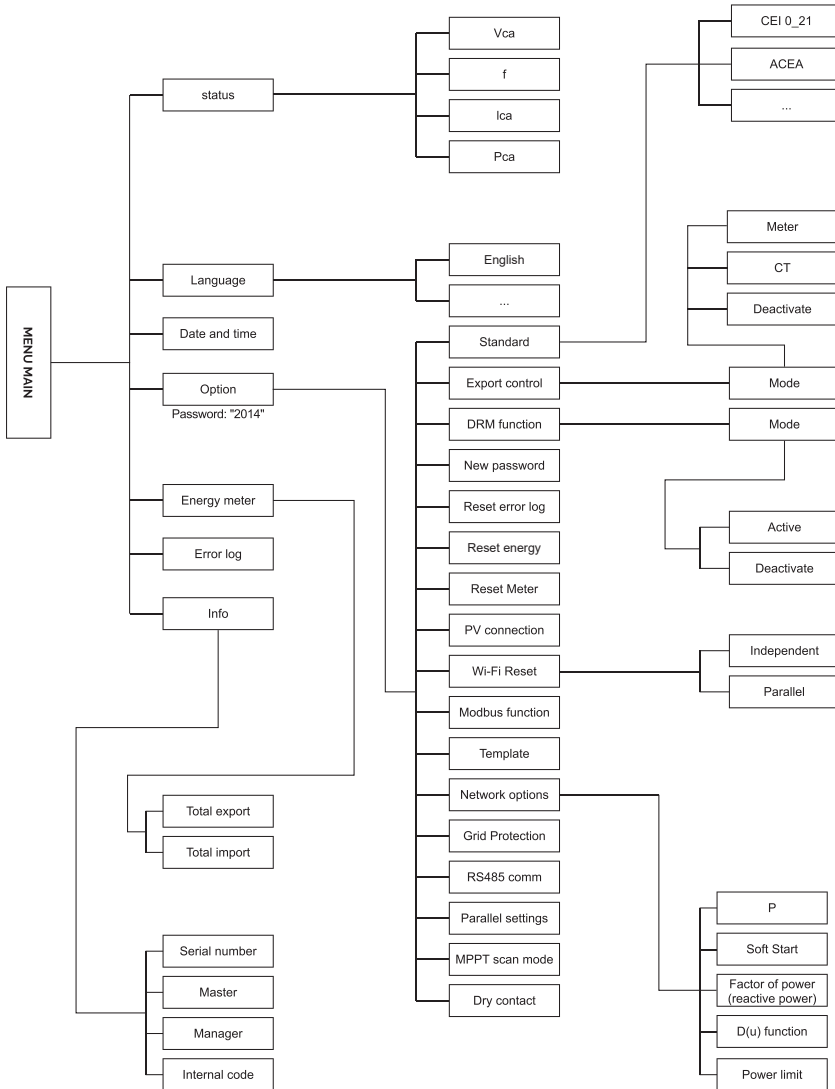

11. Main functions on display

When the inverter is turned on, the screen that appears on the display is the main one which shows the following information:

- Power = indicates the instantaneous output power
- P-Grid = indicates the energy sent to the grid or absorbed by the grid (if the value is positive, the energy is fed into the grid, if negative, the energy is taken from the grid)
- Today = indicates the energy produced during the day

(Scroll with the up and down arrows to read the information on the display)

Menu

This screen is for the user to complete the settings and obtain other information.

To enter this screen, press the "Down/Send" key of the inverter for a certain time in the main startup screen.

Choose the desired settings by scrolling them with the "Function Button" and press "Down/Send" to confirm.

State

There are two functions to choose:

a. Grid

Here the AC current parameters of the inverter such as voltage, current, output power and grid power are shown.

With "Pout" it measures the inverter output, "P grid" measures the energy exported or imported from the grid. When the value is positive it indicates the energy is fed into the grid meanwhile when the value is negative it indicates the energy is taken from the grid.

Grid	
> Ua	0.0 V
Ia	0.0 A

b. Solar

This status shows the condition of the PV system in real time, showing the parameters of input voltage, current and power status of each PV input.

Solar	
U1	0.0 V
I1	0.0 A

Language

Your device already has default language and network standards set. Check that the desired options are set or change them if necessary following the path: *MENU > LANGUAGE > Italian*.

Date and time

This function sets the date and time in the inverter.

Settings

Use this screen to access and change operating parameters of the inverter.



PLEASE NOTE

The default password is "2014", which only allows the installer to review and change the necessary settings in accordance with local rules and regulations.

1. Standard

Network standard defaults are already set on the device. Check that the desired options are set or if necessary, modify them by following the relative path:
MENU->OPTIONS->password "2014"->STANDARD



PLEASE NOTE

For inverters installed in Italy, the legislation CEI 0_21 is available in the list of standards with the parameters required by the current CEI 0-21 standard; only if the inverter is installed on the Areti - ACEA Group grid, please select the ACEA standard. The previous indications must be checked and confirmed by the network manager and by the technician who connects to the network.

2. Export Control

With this function, the inverter can control the energy fed into the grid. Choosing "Meter" in "Meter/Disable" means the user needs to install a meter

to control the energy fed into the grid. There are two values: "User value" and "Factory value". The factory value is predefined and cannot be changed by the user. The user value is set by the installer and must be lower than the factory value and in the range from 0 kW to 30 kW.

Choosing "Disable" means the function will be disabled.

For more details read the meter connection chapter of this manual

3. **DRM Function**

With this function the installer can decide whether to Enable / Disable the shutdown of the inverter via the external communication cable.

4. **Network options**

Normally it is not necessary to change these parameters, as they come automatically set by setting the correct network standard. Just in case necessary to make changes they must be in accordance with the current legislation:

Power Limit Function – Setting the AC power limit

MENU > OPTIONS > password "2014" > NETWORK OPTIONS > POWER LIMIT

This function allows you to set the percentage of power to the AC output of the inverter. The default setting is 100% (1.00).



PLEASE NOTE

This option does not enable the export limit feature of power, which allows the system to block the injection of the surplus of energy produced; for this procedure, see the Meter connection paragraph of this manual

5. **Network protection**

Typically, the end user does not need to set up network security. All default values have been set before leaving the factory in accordance with safety regulations.

If it is needed to restore the data, the changes should be made according to local network requirements.

6. **New password**

With this option it is possible to set a new password: set the new 4 digits and long press the down key to confirm.

7. **RS485 CommAddr**

By enabling this function, it will be possible to monitor the operating status of the

inverter via an external device such as a PC. The default address is "1"; when multiple inverters are monitored by a single PC, it is necessary to set the RS485 communication addresses of the different inverters.

8. **Parallel setting**

Make sure this setting is always disabled (by default it is disabled). This series of inverters do not support connection in parallel without the external device. For more details, read the chapter "Parallel connection of several inverters of the PSI-X3P-TP series" of this manual.

9. **Mppt Scan Mode**

This function shows the frequency in which PV strings are checked; 4 different modes can be selected: Off, LowFreqScan, MidFreqScan, HighFreqScan. If selected LowFreqScan the inverter (default setting) it will scan the panel according to the low frequency.

10. **Reset Energy**

By selecting it, the user can reset the energy.

11. **Reset Wi-Fi**

By selecting it, the user can reset the Wi-Fi.

12. **Model**

In this page it is possible to check the model of the inverter.

13. **PV Connection**

With this function you can select the type of connection of the photovoltaic strings. Select MULTI if the MPPTs are independent and COMM if they are connected in parallel. For more details, read the chapter "PV connection" of this manual.

14. **Dry contact**

The user can use the Dry Contact function to connect the heat pump SG Ready through an external device.

There are three functions (Disable/Manual/Smart Save) that can be selected for load management.

"Disable" > means that the heat pump is off.

"Manual" > if selected the user can control the external relay manually.

"Smart Save" allows you to set the time values and the on/off conditions of the heat pump and the operating modes.



PLEASE NOTE

If the user uses the Dry Contact function of the inverter to control the heat pump via the Adapter Box, he must refer to the Installation Guide of the Box to set its parameters.

15. Modbus Function

Choose the COM485 value to communicate with other devices via the modbus protocol.



PLEASE NOTE

To be able to make this connection, please contact the manufacturer, in order to have specific technical information.

16. Meter Energy

With this setting, the user can control the input or withdrawal of energy from the network; there are 4 parameters: Today Import, Total Import, Today Exports and Total Exports.

17. Error logs

The error log contains information about errors that have occurred (only the last 6 errors are kept in memory)

About

This interface shows the inverter information, including “Product SN”, “Master”, “Manager” and “Internal Code”. Return to the main interface.

12. Firmware Version

You can check the firmware version of the inverter by following the respective paths below:

MENU -> INFO -> MASTER (1.00 and later)

MENU -> INFO -> MANAGER (1.00 and later)

13. Configuring the PSI-X Inverter Monitoring System

13.1. Installer account creation



PLEASE NOTE

For each system, the account of the end user (owner of the system) must always be created and subsequently, if desired, it is possible to add the system created to the installer account. Not vice versa.

To obtain an installer account, please send an email to assistance@peimar.com, entering the following data:

- Company name
- Reference email address
- Username (Characters other than letters, numbers, "@", "_", "." are not allowed, there must be no spaces)
- SN of the inverter
- Tracking SN printed on the Wi-Fi module
- Password

As soon as the credentials are received from Peimar technical assistance, it will be possible to log in from the link <https://www.peimar-psix-portal.com/#/login> and possibly change the password.

To monitor the customer's system it will be necessary to go to:

To monitor the customer's system it will be necessary to go to:

Device management > New devices > + Add

and enter the monitoring SN of the Wi-Fi module, then press "Accept".

If the whole procedure has been followed correctly it will be possible, after a few minutes, to observe the production data of the customer's photovoltaic system.

13.2. Configuration via Wi-Fi module

In several models of the PSI-X series (single-phase grid inverter PSI-X1P-TL/TLM \geq 2kW, three-phase grid inverter PSI-X3P-TP, hybrid inverter PSI-X1P-HY PSI-X3P-HY and PSI-X3S- HY) a Wi-Fi module (PSI-X-H-WIFI or PSI-X-H-WIFI-3.0) is included which allows, if correctly configured, remote monitoring of the operating status and production data.



PLEASE NOTE

- If the SN of the module starts with SWxxxxxxx it is possible to carry out the connection procedure only via browser;
- If the SN of the module starts with SXxxxxxxx or SVxxxxxxx it is possible to carry out the connection procedure both via browser and via App.
- It is recommended to connect to the main Wi-Fi line since connection to repeaters / Wi-Fi does not guarantee the sending of data to the server.

13.2.1. Configuration via browser Wi-Fi module

Connection procedure

1. Insert the Wi-Fi module into its USB port on the bottom of the inverter (WIFI for PSI-X3P-HY series inverters, Upgrade/Dongle for PSI-X1P-HY and PSI-X3S-HY series inverters , DONGLE for the inverters of the PSI-X1P-TL/TLM and PSI-X3P-TP/TPM series); the LED located on the back will start flashing (LED not present in the PSI-X-H-WIFI-3.0 model).
2. Use a laptop or smartphone and look for the device's Wi-Fi hotspot which is generally called Wifi_Sxxxxxxx (Sxxxxxxx=code printed on the Wi-Fi module itself).

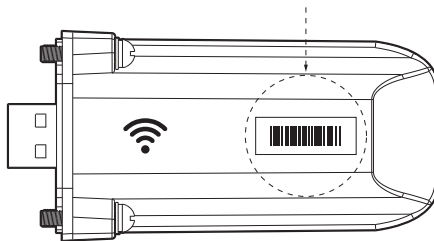

3. Connect permanently to the hotspot, click on "connect" and wait for confirmation (it is normal for the internet connection failure notice to appear).
4. Open the browser and type in the address bar <http://192.168.10.10/>.

**PLEASE NOTE**

For older inverter models, which have a PSI-X-H-WIFI stick (or for PSI-X-H-WIFI-3.0 sticks with SN starting with SX) use the address <http://5.8.8.8/> (Normally it is sufficient type in the address bar 5.8.8.8) Be careful not to connect to the address <https://5.8.8.8/>

5. Insert username "admin"
6. Insert a password:
 - "Admin" if the SN of the module starts with SWxxxxxxx
 - Code printed on the module itself if the SN of the module starts with SXxxxxxxx or SVxxxxxxx.
7. Enter the "Setting Page" click on the "Find AP" button to scan the available Wi-Fi networks.
8. Select the home Wi-Fi network, enter the relative password in the "Key" box and click on "Save"

**PLEASE NOTE**

Network name and password must contain only numbers or letters, no special characters are accepted

9. The LED of the module, where present, will start flashing rapidly; when after about 20 seconds it becomes permanently on, it means that the Wi-Fi module has connected to the router.
10. Reconnect to the dongle.
11. Reconnect to the [http](http://5.8.8.8/) address given above. Check that the data entered remained stored correctly and that there is the IP address so as to make sure that the connection was successful.

End user account creation



PLEASE NOTE

For each system, the account of the end user (owner of the system) must always be created and subsequently, if desired, it is possible to add the system created to the installer account. Not vice versa.

Once the monitoring system has been successfully configured, type in the address <https://peimar-psix-portal.com/#!/login> to create a new end user account by pressing the "Sign up" button.

Create new user ●

* SN for tracking	<input type="text" value="Insert device's serial number"/>
* Username	<input type="text"/>
* Password for accessing	<input type="password"/>
* Confirm the password	<input type="password"/>
* Status	<input type="text" value="Please select"/>
* Time zone	<input type="text" value="Please select"/>
* Plant power (kW)	<input type="text"/>
* Email	<input type="text"/>
Username	<input type="text"/>
Telephone	<input type="text"/>
* Position	<input type="text"/>

In the "Tracking SN" field, enter the code printed on the form itself and on the label applied to the box. Once all the required fields have been filled in (Italy time zone UTC +01:00), press the "Register" button to complete the registration.

Press the "Return" key and log in with the credentials you just created.

If the entire procedure has been followed correctly, after a few minutes it will be possible to observe the production data of the photovoltaic system.

13.2.2. Configuration via Wi-Fi module from app

End user account creation



PLEASE NOTE

For each system, the account of the end user (owner of the system) must always be created and subsequently, if desired, it is possible to add the system created to the installer account. Not vice versa.

1. Download the Peimar X Portal App from the store



App Store



Google
Play Store

2. Choose the language clicking on the 3 dots at the top left.
3. Press the "Create new account" button, type or scan the tracking SN printed on the Wi-Fi module itself and press the "Next" key".

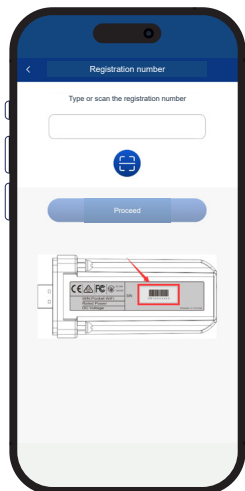

- 4 To create a new account enter the required data(Italy time zone UTC +01:00) and press "OK".

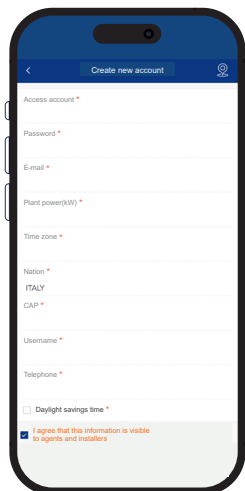

Connection procedure

1. Log in to the App with the credentials you just created.
2. Enter the User > Wi-Fi Connection section, type or scan the monitoring SN printed on the Wi-Fi module itself and press "Next".

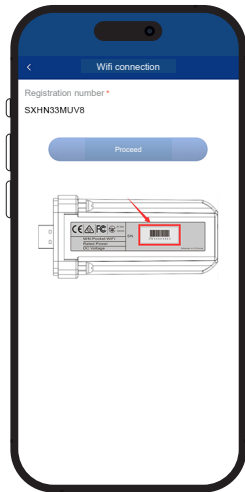

3. At the message "Peimar X portal wants to access the Wi-Fi network", press the option "Login".
4. Enter the home Wi-Fi network name (SSID) and its password.



PLEASE NOTE

Network name and password must contain only numbers or letters, no special characters are accepted

5. If the entire procedure has been followed correctly, the module LED, where present, will become permanently on and after a few minutes the app will start receiving production data from the inverter and it will be possible to view them remotely.

13.3. Config. via Ethernet cable (LAN) with PSI-X-H-ETH-3.0

If the Wi-Fi signal is too weak, it is also possible to connect to the server via an Ethernet cable. You will have to purchase the PSI-X-H-ETH-3.0 module equipped with an ethernet port, which allows the inverter to be connected via data cable to the home router (The PSI-X3P-TPM three-phase network inverter inverters already have the Ethernet module included).

Insert the Ethernet module into the relevant USB port on the bottom of the inverter (WIFI for PSI-X3P-HY series inverters, Upgrade/Dongle for PSI-X1P-HY and PSI-X3S-HY series inverters, DONGLE for PSI-X1P-TL/TLM and PSI-X3P-TP/TPM series inverters);

The installer will need to procure a Category 5e or better data cable himself.

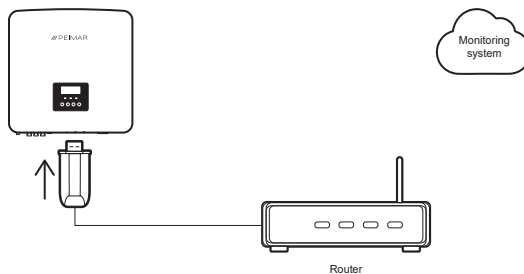

PLEASE NOTE

To complete the configuration of the monitoring system, the same procedure described in the paragraphs "Creating an end user account" must be followed for configuration via the Wi-Fi module from the browser or from the App;

the procedure described in the "Connection procedure" paragraph is not necessary as the connection is made directly via cable.

When prompted to enter the "monitoring SN", enter the code on the label of the ethernet module in place of the code on the label of the Wi-Fi module.

14. Error codes and troubleshooting

TYPE OF ERROR	RESOLUTION
TZ Protect Fault	Over current error: Check the compatibility between PV generator and inverter via designer. Check the integrity of the MC4 connectors of the photovoltaic strings.
Grid Lost Fault	Mains voltage lost: Measure the grid voltage at the inverter terminal block. Check the correct connection of the AC cable on the inverter terminal block.
Grid Volt Fault	Mains voltage overload: Measure the grid voltage at the inverter terminal block. Check the correct connection of the AC cable on the inverter terminal block. Wait a few minutes for it to return to the operating range
Grid Freq Fault	Grid frequency out of range: Wait a few minutes for it to return to the operating range
PV Volt Fault	PV overvoltage error: Check the compatibility between PV generator and inverter via designer. Check the integrity of the MC4 connectors of the photovoltaic strings.
Bus Volt Fault	PV overvoltage error: Check the compatibility between PV generator and inverter via designer. Check the integrity of the MC4 connectors of the photovoltaic strings.
GridVolt10M Fault	Grid overvoltage error: Check that you have selected the correct security code (network standard). Check the voltage drop across the AC line up to the changeover counter.
DCI NJ OCP	DCI overcurrent error: Check the compatibility between PV generator and inverter via designer. Check the integrity of the MC4 connectors of the photovoltaic strings.
SW OCP Fault	Software Overcurrent Fault: Check the compatibility between PV generator and inverter via designer. Check the integrity of the MC4 connectors of the photovoltaic strings.
Residual OCP	Over current error: Check the compatibility between PV generator and inverter via designer. Check the integrity of the MC4 connectors of the photovoltaic strings.

Iso Fault	Insulation error: Check the insulation of the AC and DC lines
Over Temp Fault	Overtemperature error: Check the place of installation of the devices
OverLoad Fault	Network Load Overload Error: Turn off high power devices and restart the inverter.
Fan Fault	Fan error: Check that foreign material has not caused damage to the impeller
Low Temp Fault	Under temperature error: Check the place of installation of the devices
AcTerminalOTP	AC terminal overtemperature error: Check that the terminals are correctly tightened Check the ambient temperature Check the place of installation of the devices
Other Device Fault	External device error: Update the inverter to the latest firmware version and restart.
Internal Com Fault	Internal communication error Restart the entire system. Perform software update Reset the inverter
Eeprom Fault	Inverter DSP EEPROM error: Restart the entire system Disconnect and reconnect the PV connectors
RCDevice Fault	Residual current error Restart the entire system. Perform software update
Grid Relay Fault	Network Relay Error: Check network connections Restart the entire system.

PV ConnDirFault	PV string polarity error: Check the correct polarity of the MC4 connector with the photovoltaic strings
MGR EEPROM Fault	Inverter ARM EEPROM error: Restart the entire system Disconnect and reconnect the PV connectors
PowerTypeFault	Power Failure: Check for firmware updates.
Meter Fault	Meter error: Check the correct installation of the meter/TA
Fan1 Warning	Abnormal operation of fan 1: Check that the fan is working properly
Fan2 Warning	Abnormal operation of fan 2: Check that the fan is working properly

15. Periodic maintenance

In most cases, inverters do not need any maintenance or repairs, but if the inverter often loses power due to overheating, the problem may be due to the following reasons:

- The heat sink on the back of the inverter is dirty. If necessary, clean it with a soft, dry cloth or a brush (repeat this operation approximately every 6 months to maintain the inverter correctly). Only trained and authorized professional personnel who are familiar with the safety requirements may carry out maintenance.
- That the input and output cables are in good condition and not damaged (do this check at least every 6 months).

16. Disposal



This device MUST NOT be disposed off as municipal waste.

The crossed-out wheeled bin symbol on the device label indicates that the product at the end of its useful life must be collected separately from other waste to allow for proper treatment and recycling. The user will therefore have to deliver the equipment that has reached the end of its life free of charge to the appropriate municipal centers for the separate collection of electrical and electronic waste, or return it to the dealer according to the 1 against 1 method when purchasing a new equivalent product. Adequate separate collection for the subsequent sending of the decommissioned equipment to environmentally compatible recycling, treatment and disposal helps to avoid possible negative effects on the environment and health and promotes the re-use and/or recycling of the materials it is made of the equipment. Illegal disposal of the product by the user involves the application of the sanctions referred to in current legislation.

17. Warranty conditions

For the warranty conditions, refer to the relative document which can be downloaded from the website www.peimar.com

/// PEIMAR



info@peimar.com | www.peimar.com